



MAX, ECOVENT, PM and WP

Installation, Operation and Maintenance Manual

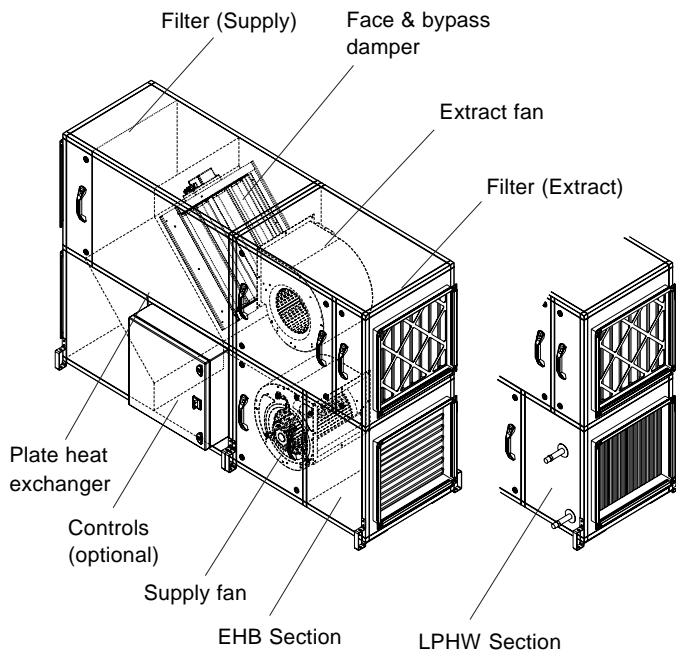



Fig. 1 Typical unit layout

IMPORTANT 
 This manual must be read in full before Installation, Operation and Maintenance of the units supplied

Contents		page
1	Introduction	1
2	Receipt of Goods/Handling	1
3	Installation	1
4	Set-up	3
5	Wiring	4
6	Maintenance	8
7	Warranty	9
8	Declaration of Conformity	10

1 Introduction

The MAX and ECOVENT series are a range of units, direct and belt driven, with duties up to 20m³/s. Suitable for plant-room, ceiling void and external locations, each unit will have been supplied with either no pre-wiring, pre-wired to an external isolator or with fitted control panel as specified at the time of order. The standard operating temperature of these units is -20 to +35°C.

For further technical details regarding dimensions and weights, contact VES on **08448 15 60 60**, quoting the sales order (SO) number and the unit type as found on the unit nameplate or visit **www.ves.co.uk**.

2 Receipt of Goods/Handling

Immediately upon receipt of goods, check for possible damage in transit paying particular attention to fan impellers, motor, flexible connections, coil connections and unit casing. Prior to installation please check to ensure smooth rotation of the impeller after transit. Also check to ensure that any ancillary items are included. These will normally be supplied fitted or, in the case of small items, taped to the unit.

In the event of any damage having occurred or if any item is found to be missing, it is essential to inform VES Andover Ltd. within **3 working days** of delivery quoting sales order

number and the unit type, as found on the unit nameplate. After this period, we would be unable to accept any claim for damaged or missing goods.

IMPORTANT 
 Handles, lids, housings and coil connections must not be used as lifting points

When moving the unit, handle with care and in such a manner as to avoid damaging the external finish as this may reduce the ability to resist corrosion. Units are to be rigged and lifted using spreaders, taking into account the weight of the unit, and lifting gear should be arranged so as not to bear on the casework.

For further details, refer to the unit outline drawing.

3 Installation

The entire system must be considered for safety purposes and it is the responsibility of the installer to ensure that all of the equipment is installed in compliance with the manufacturer's recommendations, with due regard to the current HEALTH AND SAFETY AT WORK ACT and conforms to all relevant statutory regulations.

Where a unit is installed so that a failure of components could result in injury to personnel, precautions should be taken to prevent such an injury. If the unit is installed where there is a reasonable possibility of persons or objects coming into contact with the impeller, a guard should be fitted.

It is the installer's responsibility to ensure that access panels are not obstructed in any way and safe working access for maintenance must be provided. For optimum unit performance, careful consideration must be paid to the location of the unit in relation to the ductwork and associated items; placing the unit directly adjacent to a bend in ductwork will impede airflow and reduce performance. Consideration must also be given by the installer for adequate illumination of the unit location in order for safe maintenance.

Sectional (tubular framed) units should be assembled using self-adhesive rubber tape at the joints prior to assembly so as to prevent air leakage; replace with similar if damaged.

IMPORTANT 
 Only experienced fitters should undertake this work. Take necessary safety precautions when working in elevated positions

Electric Heater Batteries

Supply to the heater should be 1ph or 3ph with separate neutrals; confirmation of this can be found on the unit nameplate. Cables should be of silicone rubber, fibreglass or of a similar high temperature insulated type and be installed to current I.E.E. Regulations, ensuring a sufficient earth connection to the terminal provided. Care should be taken not to overstrain the terminal pillars as this may permanently damage the elements.

The heater is fitted with a manual reset high temperature cut-out with normally closed (NC) terminals. The cut-out is set to break if the duct temperature rises above 130°C and must be connected in series with the main contactor coil circuit if the heater is to be isolated in the event of overheating.

The electrical supply must be isolated before attempting to reset the manual cut-out.



MAX, ECOVENT, PM and WP

Installation, Operation and Maintenance Manual

IMPORTANT



In order to prevent overheating within the unit and consequent damage to integral components, a 2-5 minute fan run on timer should be incorporated into the control circuit.

The elements are tested prior to dispatch and are within a tolerance of 7.5W. In the event that elements should be found to be faulty they can be easily removed and replaced.

To remove the electric heater battery, take out the fixings from the element tray and slide the assembly free. Elements that are stored in damp conditions may need drying to attain correct insulation readings. For further technical details contact **VES Customer Services Department**, quoting the sales order (SO) number and the unit type as found on the unit nameplate.

Drain Pan Trap

Where a drain pan is fitted, please refer to trapping detail manual: 'VES Ref: ID665' 'Drain Trap Installation'.

Water Coils

Low Pressure Hot water (LPHW) coils should have an air vent and drain plug located on the pipe work immediately adjacent to the AHU: they are not fitted to the coil.

The air vent should be at the highest point, with the drain at the lowest. When the coil is at a high point of the system it should be regularly vented so as to avoid potential air locks resulting in a fall off of duty. It is important that water coils are protected against damage from extreme weather conditions during the winter season. If the water is allowed to freeze in the coil system, damage may occur potentially bursting pipes and resulting in emergency problems. This can be prevented by fitting a frost thermostat at the unit inlet and ensuring that boilers run continuously in low ambient temperatures.

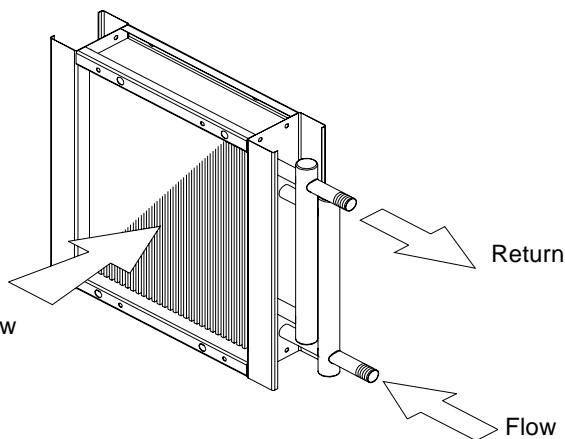

Fig.2 Water Coil Connections

It is recommended that a check be made as to whether any treatment is required to the water supply for prevention of corrosion and scaling of the equipment. Information regarding the necessary action to be taken can be obtained from the relevant Water Supply Authority.

Steam Coils

Steam coils are suitable for use with saturated steam up to 100psi. The pipe work must be so arranged to provide adequate drain lines with a suitable strainer and steam trap. All steam and drain lines should be lagged. The supply should be taken from the top of the steam main, to avoid the introduction of moisture or air into the coil. The pipe shall be arranged so that it does not interfere with the coil expansion. Where steam coils are fitted it is essential that a time delay is installed in the fan starter control circuit.

The fan shall be kept running for at least two minutes after the steam supply to the coils has been shut off, so that residual heat of the coil is dissipated.

If the pipe run is unduly long and prone to water logging, it should be properly trapped, just before the coil. If the steam is from a high pressure steam main, it is essential to have a working pressure relief valve on the low side to ensure that dangerous overheating of the air and excessive pressure cannot occur.

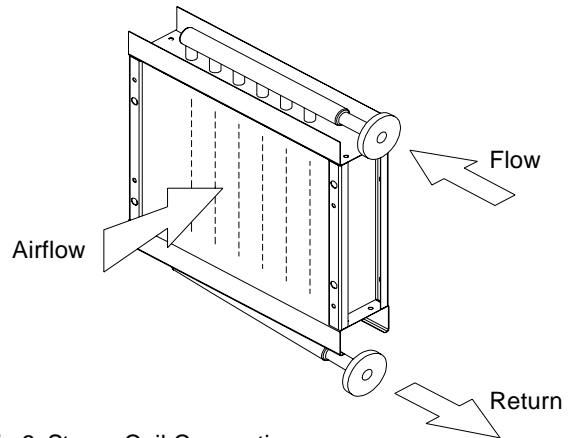

Fig.3 Steam Coil Connections

DX Coils

DX and Condenser Coils must be connected to systems in accordance with accepted refrigeration codes of practice and if fitted upstream to steam or water coils, care must be taken to ensure that the air temperature does not drop below 0°C.

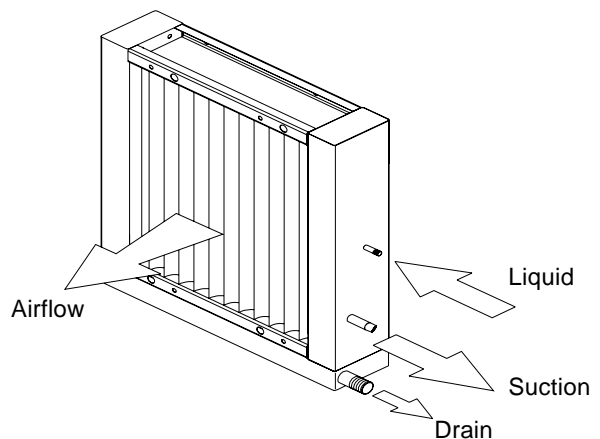

Fig.4 DX and Condenser Coil Connections



MAX, ECOVENT, PM and WP

Installation, Operation and Maintenance Manual

IMPORTANT



Should it be necessary to remove any slide-in component, ensure that these are secured into position once reinstalled to prevent untreated air bypass

Where provided, flanges and spigots should not be used to support the ductwork and used solely as a means of ductwork connection. Further consideration should be given to the unit's position and secured into place as appropriate. This is especially important with external mounting as the wind and elements may effect the overall stability of the unit.

4 Set-up

Motor and electrical details must be checked prior to connection to mains supply. All motor information can be found on the unit data sheet, supplied attached to the unit. Units with direct drive fans should be subject to a check that the impeller blades are not damaged and spin freely.

Units with belt driven fans should be checked to ensure that the transit bolts and spacer are removed from fan and motor frames. These are used to protect the anti-vibration mounts and flexible connections during delivery, and must be removed for these items to be effective.

Ensure correct pulley alignment as indicated in *fig.5* below. To check the tension of the drive belt apply a force perpendicular to the centre of the belt span sufficient to deflect the belt 16mm for every metre of span length, as indicated in *fig.6*. The force required to deflect the belt should be from 0.5 to 0.8kg. Do not over tighten the belts as this will damage the bearings in both fan and motor. After the unit has been positioned, re-check that the impeller is smooth running as this may have moved during transit.

5 Wiring

IMPORTANT



Electrical supply must be fully isolated before attempting to affect any work on this unit

All electrical connections to any unit must be carried out in accordance with the current edition of the I.E.E REGULATIONS and only competent Electricians should be allowed to affect any electrical work to our units.

IMPORTANT



Do not connect any unit to an electrical supply voltage outside of that indicated on the motor name plate

The following wiring diagrams are a guide to installing the standard fan, motor and actuator options found on the MAX and ECOVENT units. If in any doubt, or for special versions of the units, consult the wiring diagram in your document pack or contact our customer services department on **08702 404340**, quoting the sales order (SO) number and unit type as found on the unit name plate.

IMPORTANT



It is essential that all electrical connections are properly made

A trial connection of the three phase supply should be made to check that the fan rotates in the correct direction as indicated on the fan. If the rotation is incorrect, interchange any two phases of the incoming supply at the terminal block.

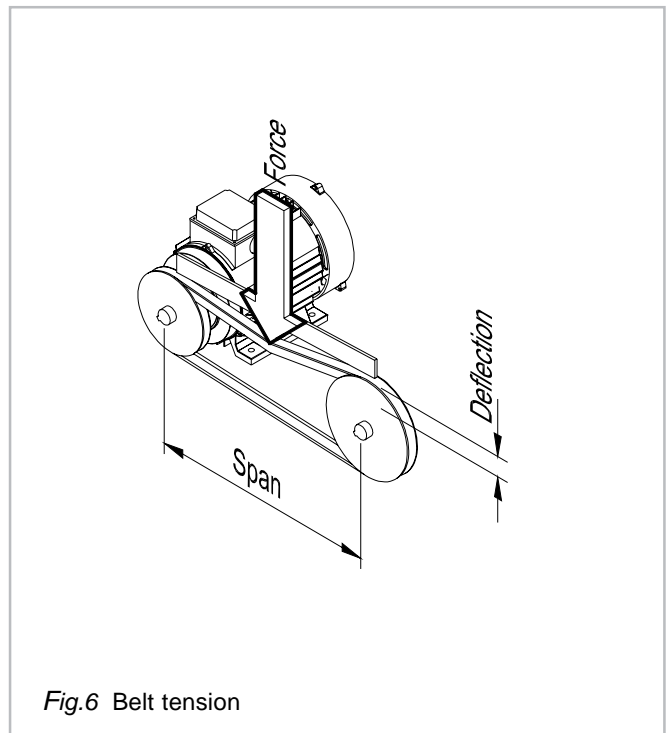
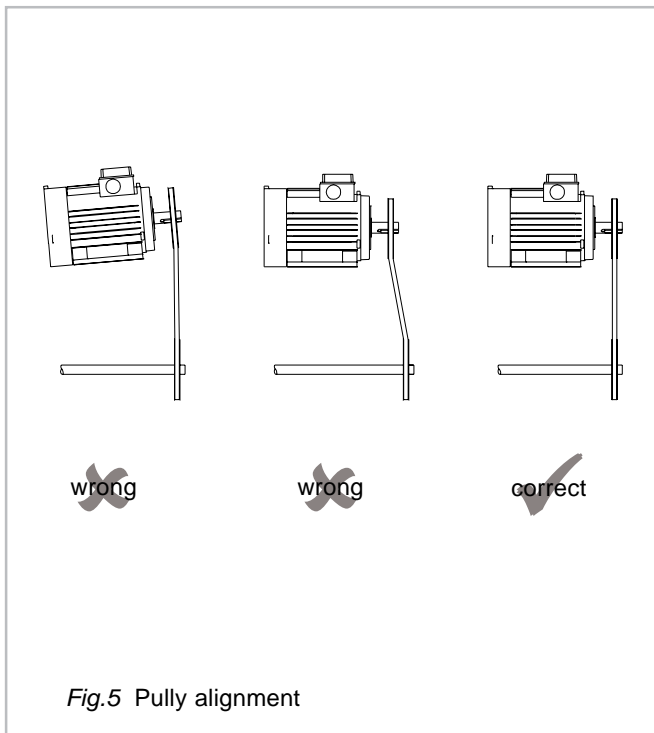



MAX, ECOVENT, PM and WP

Installation, Operation and Maintenance Manual

5 Wiring *continued*

Standard fan wiring arrangement

Fig.7 230v 1Ph 50Hz

ECOVENT Units:
13 and 14 Only

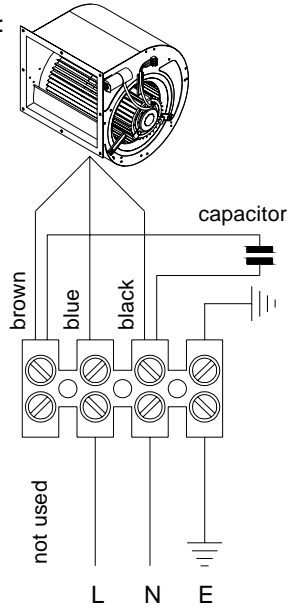

ECOVENT Units:
25, 26, 35, 36
46, 47, 56, 57.

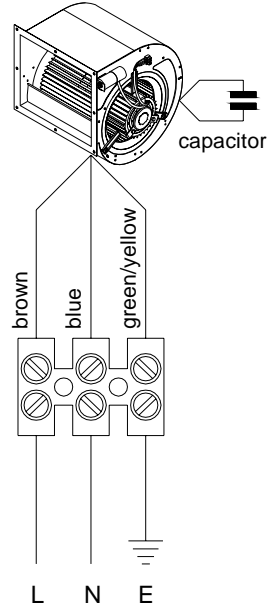

Standard motor wiring arrangement

Fig.8 230v 1Ph 50Hz

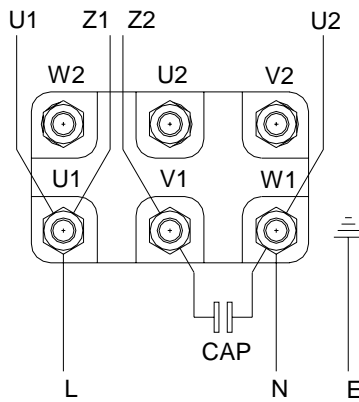
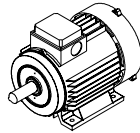

To identify your fan, please check your unit model code against the unit name plate



MAX, ECOVENT, PM and WP

Installation, Operation and Maintenance Manual

5 Wiring *continued*

Standard motor wiring arrangement

Fig.9 400v 3Ph 50Hz

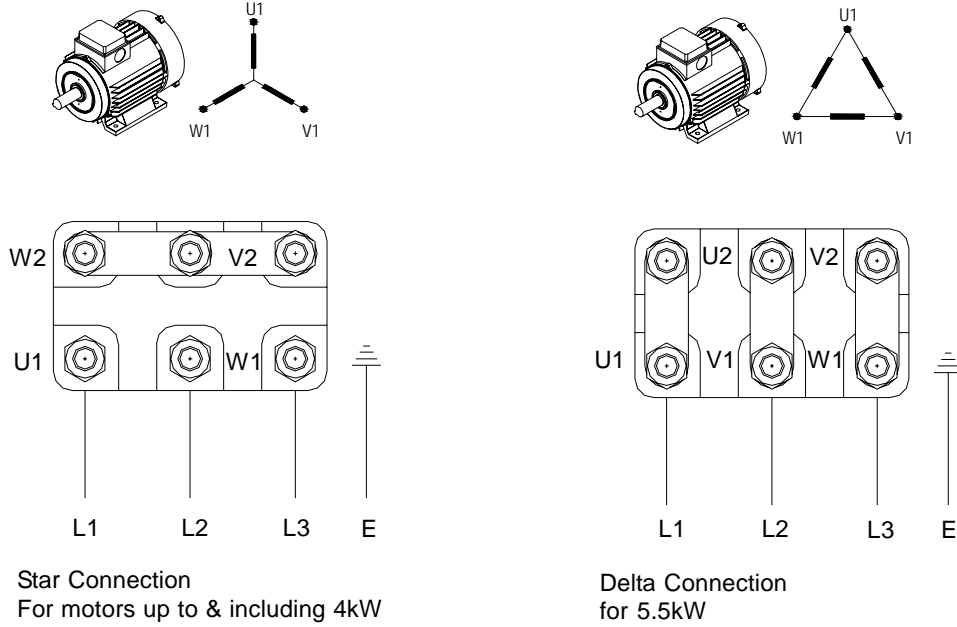

Standard motor wiring arrangement

Fig.10 400V 3Ph 50Hz

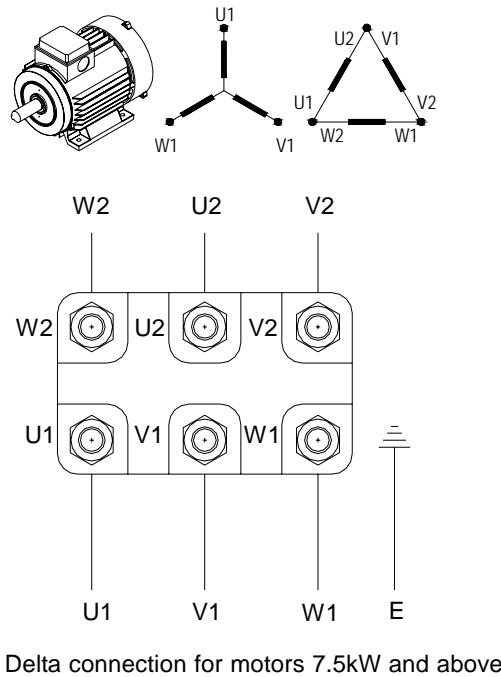

Note: A trial connection of the three phase (3Ph) supply should be made to check that the fan rotates in the correct direction as indicated on the fan. If the rotation is incorrect, interchange any two phases of the incoming supply at the terminal block. Where the above motors are used in conjunction with inverters, please refer to the appropriate inverter wiring diagram.



MAX, ECOVENT, PM and WP

Installation, Operation and Maintenance Manual

5 Wiring continued

Standard motor wiring arrangement

Fig.11 2 Speed dual wound motor, 400V 3Ph 50Hz

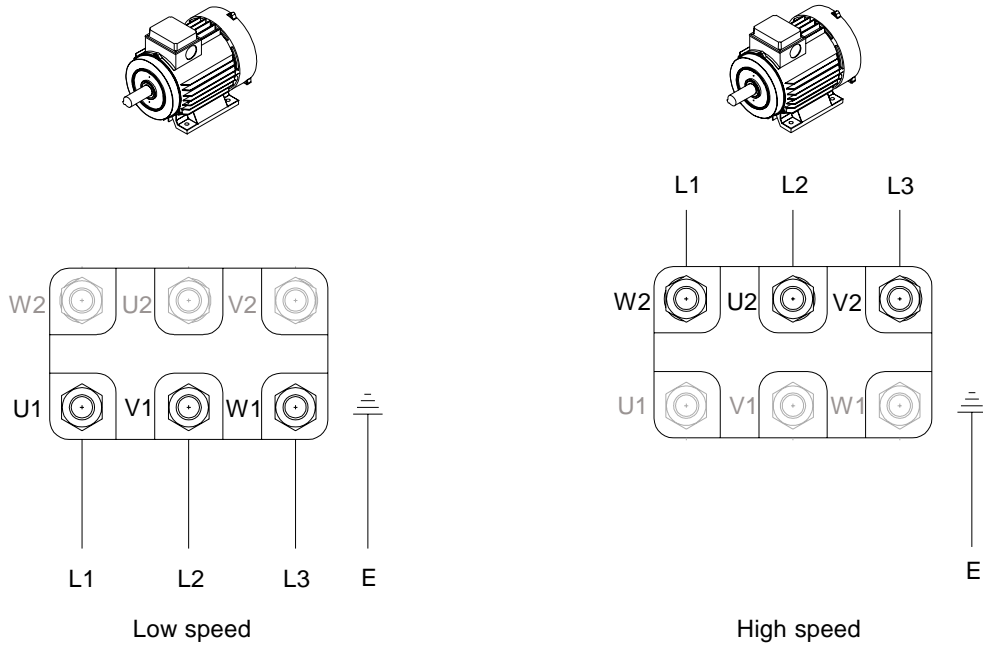

Standard motor wiring arrangement

Fig.12 2 Speed dual wound motor, 400V 3Ph 50Hz

Star (Low speed)
 Star/Delta connection (High speed)

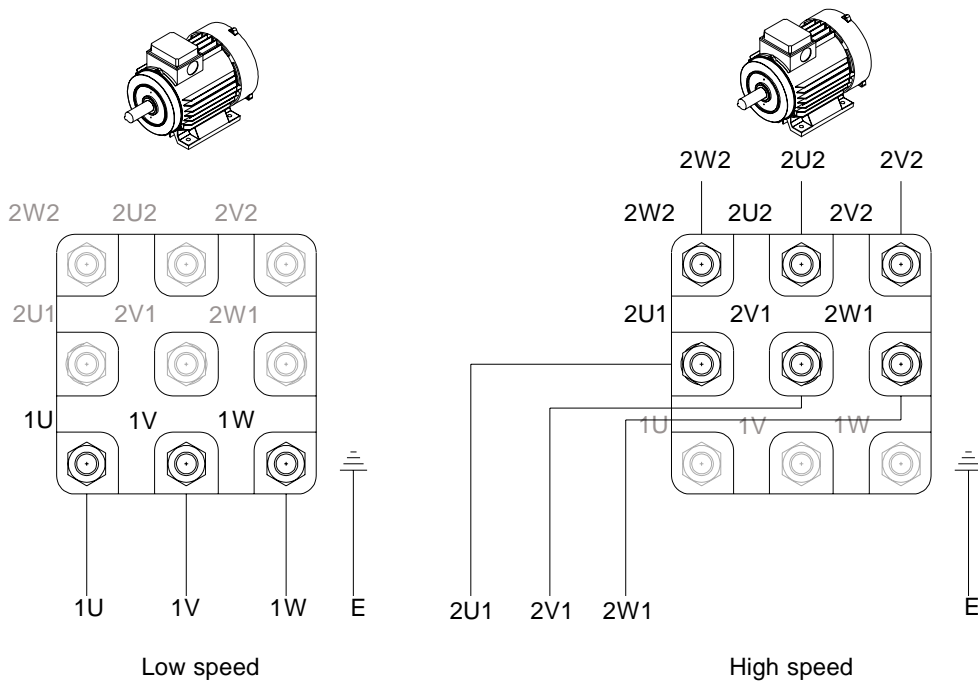

Note: A trial connection of the three phase (3Ph) supply should be made to check that the fan rotates in the correct direction as indicated on the fan. If the rotation is incorrect, interchange any two phases of the incoming supply at the terminal block.



MAX, ECOVENT, PM and WP

Installation, Operation and Maintenance Manual

5 Wiring continued

Standard actuator wiring arrangement

Fig.13 230V 1Ph 50Hz
 24V 1 Ph 50Hz

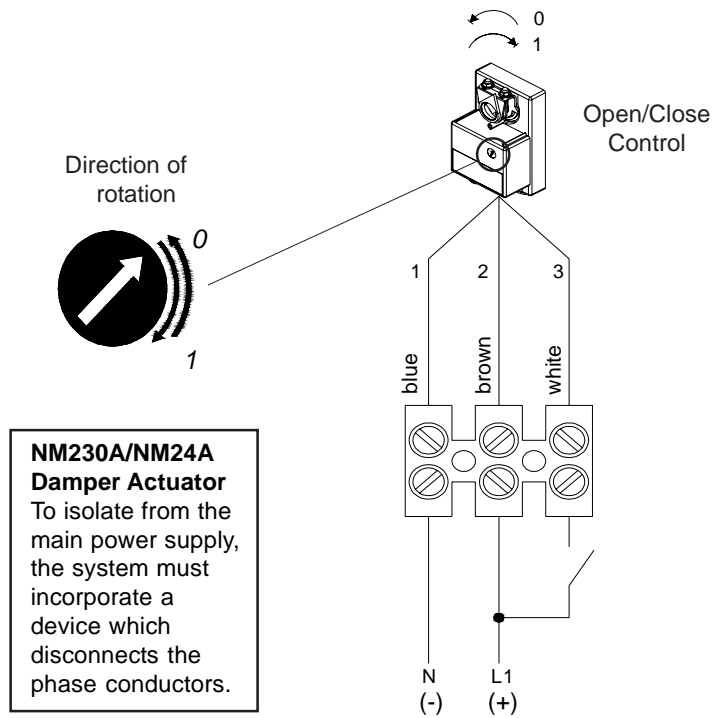

Standard motor wiring arrangement

Fig.14 Standard wiring arrangement to local isolator

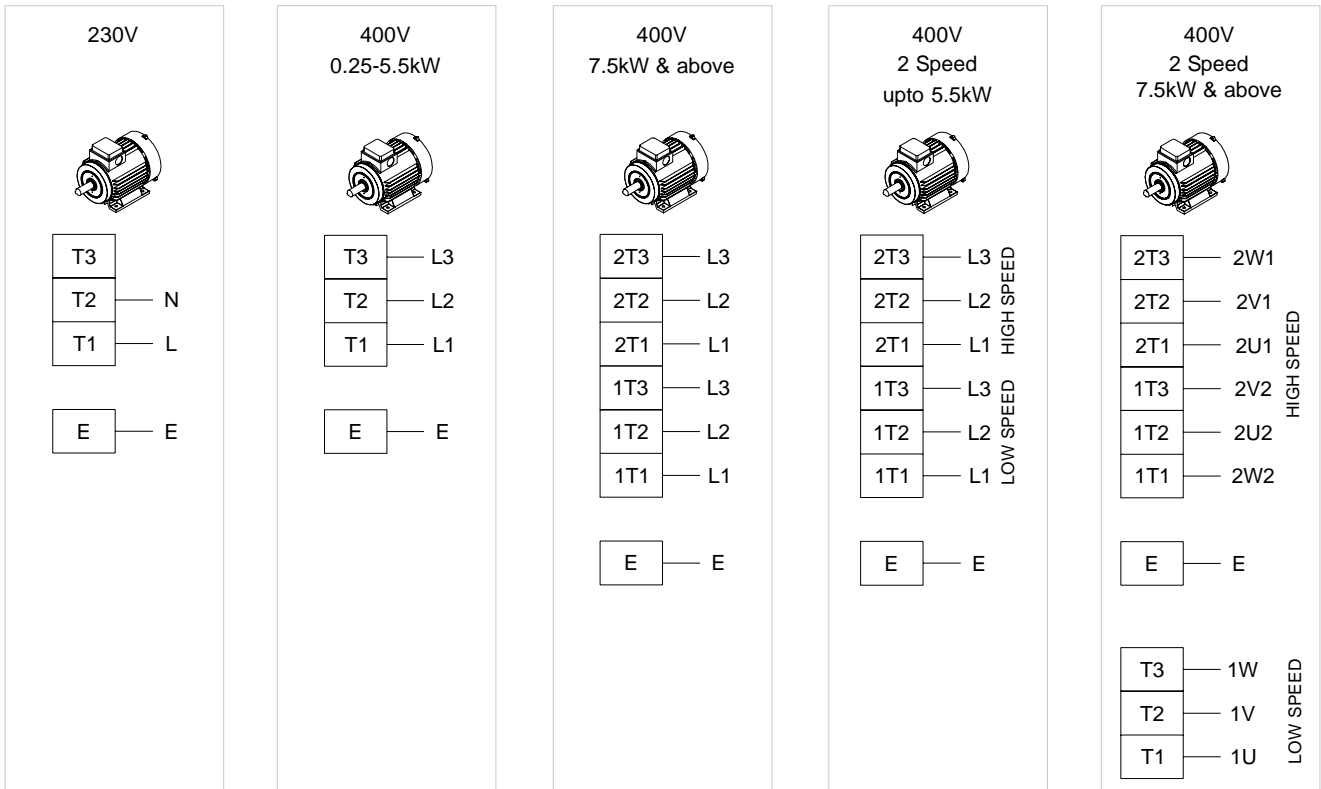

For pre-wired run & standby configuration please refer to VES Technical Department for further details.



MAX, ECOVENT, PM and WP

Installation, Operation and Maintenance Manual

6 Maintenance

IMPORTANT

Before attempting to carry out any maintenance work, investigative or repair work on our units, the unit **MUST BE COMPLETELY ISOLATED** from its electrical supply. Ensure a minimum of two minutes after electrical disconnection before removing access panels. This will allow any moving parts to come to a rest

In general, these units require little maintenance. All fan and motor bearings are supplied fully greased and lubricated. In the unlikely event of component failure, spares are available from stock at VES Andover Ltd.

WARNING

When used in conjunction with an inverter for speed control, a minimum of 5 minutes should be given to allow for the capacitors to discharge before starting work after disconnection from the power source

IMPORTANT

Before attempting to carry out any work on our units, all accompanying documentation including warning labels on the unit must be referenced

Three Monthly Check

The belt drive should be thoroughly checked. Belts are subject to fatigue and will stretch over a period of time. Again, within normal operating conditions, belts tend to stretch in the first few days of running; inspection of belts at this early stage is advised. After this initial period, regular 3 monthly checks should be made. If belts are found to be loose or worn, retighten or replace as necessary. Refer to *fig.6* for the recommended tension.

Do not mix belts. If two or more belts are used make sure that all are replaced at the same time. Excess wear on the side of belts indicates misalignment of the pulleys and should be rectified at once see *fig.5*.

Filters should be inspected regularly. If they are found to be heavily soiled or damaged they should be replaced immediately.

The general operation of the unit should be inspected, particularly for noise from bearings, motors and fans. An irregular noise could signify that unit failure is imminent.

Six Monthly Check

As above, plus:

Check for dust build-up in the system, especially around the impeller. Remove the dust if necessary. Failure to do this periodically could lead to a loss of performance or cause the fan to become out of balance, ultimately leading to bearing failure.

Coils should be inspected every six months to ascertain if any foreign matter has accumulated between the fins and that the coil connections are free from any leaks.

Should any matter be found, the coils should be cleaned using a soft brush and mild solution of commercial detergent. If heavily contaminated, a steam lance may be used.

IMPORTANT

Care should be taken so as not to damage or distort the fins during this cleaning process.

The face and bypass damper should be afforded some protection by the unit filtration. If required, clean blades, cogs and frames, and lubricate with a PTFE aerosol lubricant or equivalent.

Plate heat recovery units have no moving parts, therefore only minimal maintenance is required. Periodically inspect heat exchange matrix for any debris, dust or dirt build up. Frequent contamination might be as a result of poor filtration and should be investigated. A reduction in filtration quality can be caused by factors such as sagging of filter media, due to excess moisture or rips and tears in the material.

If found to be contaminated, foreign matter should be removed by one of the following methods; Superficial dust or debris can be removed from the surface of the heat exchange matrix by gently brushing. Loosened debris can then be vacuumed from the surface of the matrix, or flushed through with warm water.

Stubborn deposits can be removed by using a low pressure washer with an approved detergent solution. The solution temperature should not exceed 50°C. When using any pressure device care must be taken not to damage the heat exchange matrix. Under NO circumstances should the heat exchanger be steam cleaned.

Should a full service be required it may be necessary to disassemble the unit casework to gain access to the heat exchanger.

Annual Checks

MAX and Ecovent units are supplied with either unpainted galvanized sheet steel or powder coat paint finishes. Check all painted items to ensure that they have not deteriorated. Repaint as necessary. Paint can be supplied upon request. Checks should be carried out for missing fasteners

IMPORTANT

Should it be necessary to remove any slide-in component ensure that these are secured into position once reinstalled. It is critical that after any maintenance work has been conducted that all components removed/replaced be refitted correctly by a competent engineer

WEEE Directive



At the end of their useful life the packaging and product should be disposed of via a suitable recycling centre. Do not dispose of with normal household waste. Do not burn.

When enquiring after, or ordering spares contact VES Spares Department, quoting the sales order (SO) number and unit type as found on the unit nameplate.

Telephone 08448 15 60 60
Fax 023 8026 1204



PLEASE ENSURE THAT THIS DOCUMENT IS PASSED ON TO THE END USER.

We reserve the right to alter the specification without notice

©VES Andover Ltd. 2007

No part of this publication may be photocopied or otherwise reproduced without the prior permission in writing of VES Andover Ltd.



MAX, ECOVENT, PM and WP

Installation, Operation and Maintenance Manual

7 Warranty

Extended Warranties

All VES Andover Products come with a one year guarantee from date of dispatch, which covers parts and labor. You can now extend this with the following options:

Option 1. **FREE extended Warranty**

We can offer you a maintenance agreement that keeps this equipment in tip-top condition. If you take out this agreement, we will extend the warranty **free of charge for up to 5 years**, providing the regular maintenance agreement remains in place.

Option 2. **12-24 Month Extended Warranty**

12-24 months from the date of dispatch. This can be covered at a cost of just 3% of order value. (minimum charge £50.00).

Option 3. **12-36 Month Extended Warranty**

12-36 months from date of dispatch. For this cover, the charge is 6% of order value (Minimum charge £80)

Please State which option you require when you place your order. A transferable certificate will then be issued to you. *Please note, this offer excludes condensing units. We would be happy to quote you for these separately.*

Register for separate spares reminders and get a 10% discount

Register for this free service and we will automatically send you a regular reminder detailing the consumable spares for this unit, together with their current list prices.

You will then be entitled to a 10% discount off any spares.

To arrange any of these options.

or **Phone: 08448 15 60 60**
 Email: spares@ves.co.uk

Stating the sales order and reference number from the unit.



MAX, ECOVENT, PM and WP

Installation, Operation and Maintenance Manual



Declaration of Conformity

Date: 23 June 2006
Product: ECOVENT and Max Heat Recovery Units
Type: ECO
Manufacturer: VES Andover Limited

The product above is produced in accordance with EC Council Directives:

98/37/EC (Machinery Directive)
2004/108/EC (Electromagnetic Compatibility Directive)
73/223/EEC and amendment 93/68/EEC (Low Voltage Directive)

The European Harmonised Standards applied are:

BS EN ISO 12100, EN 294, EN61000, EN 60204-1

The National Standards applied in particular are :

BS 848 Part 1

Basis of Self attestation:

Quality Assurance to ISO 9001-2000, BSI Reg. Firm Cert. No. Q5375

Signature of Manufacturer:

Position of Signatory:

Technical Director