

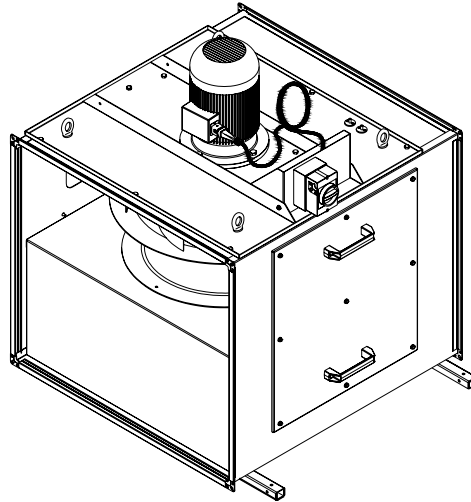

# T-Line 90 & 120 Extract Units

Installation, Operation and Maintenance Manual





**Important**  This manual must be read in full before installation, operation and maintenance of the units

Please ensure that this document is passed to the end user. This manual forms an integral part of the product and should be kept for the working life of the product. Additional copies of this and supporting documents are available by contacting VES or by visiting [www.ves.co.uk](http://www.ves.co.uk) and following the 'Download O & M's' link.

The following symbols used within this document refer to potential dangers or advice for safe operation

Warning  Indicates hazards associated with electric current and high voltages

Caution  Indicates hazards that require safety advice for personnel and/or potential unit/property damage

Important  Indicates important information

Contents	Page
1 Introduction	2
2 Unit Description	2
3 Receipt of Goods/Handling	3
4 Installation	3
5 Set-up	6
6 Wiring	8
7 Controls	14
8 Installation and Commissioning	22
9 Basic Control Panel	23
10 Terminal Connections	24
11 Installation Checklist	25
12 Start-up	25
13 Preprogrammed Faults	29
14 Fault Tracing	30
15 Maintenance	31
16 Declaration of Conformity	35
17 Warranty	36

# T-Line 90 & 120 Extract Units

## Installation, Operation and Maintenance Manual

### Introduction 1

The T-Line is a range of direct drive duct mounted extract fans, designed typically for arduous conditions i.e hot air with high grease content. The standard ambient operating temperature of the unit is -20 to +35°C, with in-duct airflow temperature up to 90°C for the T-Line 90 unit and up to 120°C for the T-Line 120.

For further technical details regarding dimensions and weights, contact VES on **08448 15 60 60**, quoting the sales order (SO) number and the unit type as found on the unit nameplate or visit [www.ves.co.uk](http://www.ves.co.uk).

### Unit Description 2

Part Number Coding:

Point description	Point Variants	Unit type	Details
1 Product	TLL	90 & 120	T-Line Extract Unit
2 Unit Size	250	120 only	Unit size determined by impellor size
	350	90 & 120	
	400	90 & 120	
	450	90 & 120	
	500	90 & 120	
	560	90 & 120	
	630	90 & 120	
	710	90 & 120	
3 Number of motor poles	/4	90 & 120	4 Pole
	/6	90 & 120	6 Pole
4 Motor efficiency	1	90 & 120	IE1 (EFF2)
	2	90 & 120	IE2 (EFF1)
5 Phase	-1	90 & 120	Single Phase
	-3	90 & 120	Three Phase
6 Unit configuration	/PH	90 & 120	Plantroom straight through
	/PL	90 & 120	Plantroom c/w bottom inlet
	/WH	90 & 120	Weatherproof straight through
	/WL	90 & 120	Weatherproof c/w bottom inlet
7 Colour	Null	90 & 120	Galvanised plantroom / RAL7004 weatherproof
	R7004	90 & 120	Powder coat finish to any colour
8 Powder coat type	Null	90 & 120	Galvanised plantroom/ RAL7004 weatherproof
	/IT	90 & 120	Internally only as colour
	/BT	90 & 120	Both internally and externally coated as colour

Typical example

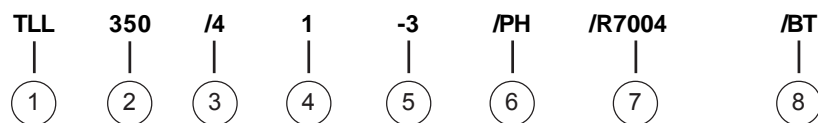

# T-Line 90 & 120 Extract Units

## Installation, Operation and Maintenance Manual

**Receipt of Goods 3** Immediately upon receipt of goods, check for possible damage in transit. Also check to ensure that any ancillary items are included. These will be supplied fitted or taped to the unit (in the case of small items). In the event of any damage having occurred or if any item is found to be missing, it is essential to inform VES within **3 working days** of delivery, quoting the sales order (SO) number, and the unit type as found on the unit nameplate. After this period we will be unable to accept any claim for damaged or missing goods.

**Important**  The unit should NOT be lifted by handles, lids, housings, shaft, motor or drive.

When moving the unit, handle with care and in such a manner limiting damage to the casework. Particular care must be taken when moving weatherproof units, any damage to the external powder coat finish may reduce the ability to resist corrosion. Units are to be rigged and lifted using spreaders, taking into account the weight of the unit, lifting gear should be arranged so as not to bear on the casework.

### Installation 4

**Caution**  Only experienced engineers should undertake this work.

Safety for the entire system must be considered when installing the unit and it is the responsibility of the installer to ensure that all of the equipment is installed in compliance with the manufacturer's recommendations, with due regard to the current HEALTH AND SAFETY AT WORK ACT and conform to all relevant statutory regulations. Precautions should be in place so that in the unlikely event of component failure the risk of personnel injury is reduced. For optimum unit performance, careful consideration must be paid to the location of the unit in relation to the ductwork and associated items; i.e placing the unit directly adjacent to a bend in the ductwork will impede airflow and reduce performance.

#### Lifting and Connecting to Duct

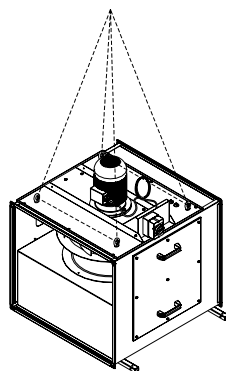

Secure lifting cable through the lifting lugs. Ensure fan plate is securely in place before lifting the unit.  
 It is recommended that the unit is lifted using the supplied lifting lugs.

#### Duct Connections

**For illustration purposes only**

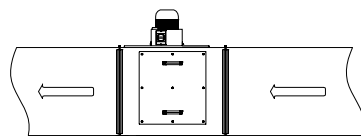

Recommended

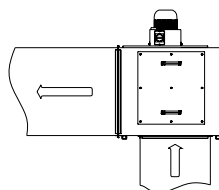

Recommended

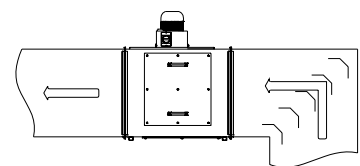

Recommended only with fitted turning vanes

# T-Line 90 & 120 Extract Units

Installation, Operation and Maintenance Manual

## Installation 4

Continued

**Caution**  Units should only be supported using the support feet as provided by VES with the unit. Contact VES before attempting to support the unit using alternative methods. Only experienced engineers should undertake this work. Take necessary safety precautions when working in elevated positions.

The T-Line unit is designed to be mounted in a range of orientations. The unit can be suspended from the ceiling using drop-rods, or bolted to the plant room floor. It is the installer's responsibility to ensure that there is safe working access provided to the unit for maintenance. The installer must also consider, adequate illumination of the unit, in order for safe maintenance to be carried out.

### T-Line Unit Orientation

#### All Sizes

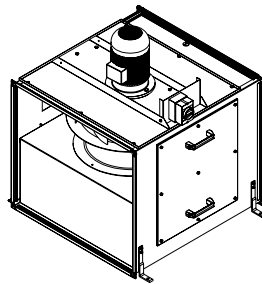

- Motor on top
- Access on both sides
- Feet mounted on bottom

#### 250 -630 only (not for 710 and 800)

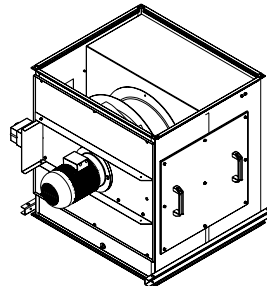

- Motor on side
- Access on both sides
- Feet mounted either side of the access sides

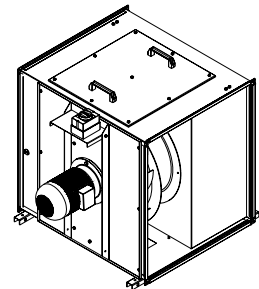

- Motor on side
- Access on top only and bottom
- Feet mounted on bottom access side

**Warning**  The electrical supply must be fully isolated before attempting to complete any work on this unit. All electrical connections to any unit must be carried out in accordance with the current edition of the I.E.E Regulations and only competent electricians should be allowed to carry out any electrical work to our units.

### Fixing Feet

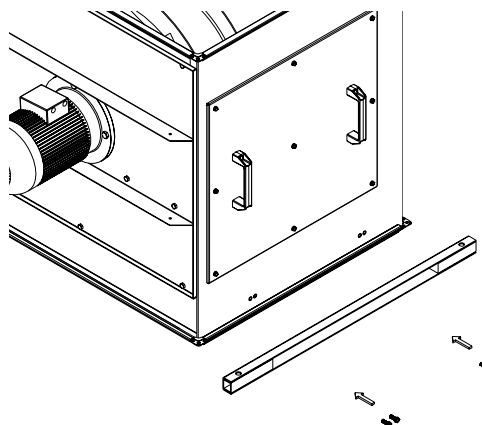

NOTE: Fix mounting feet to the correct side dependant on the orientation of the unit.

# T-Line 90 & 120 Extract Units

## Installation, Operation and Maintenance Manual

### Installation 4 Continued

Changing the handing of the isolator consists of un-plugging the isolator after it is fully isolated, remove the bracket fixings, re-attaching the bracket to the opposite side and then connecting the plug back into the motor.

Handing Isolator  
 Plate

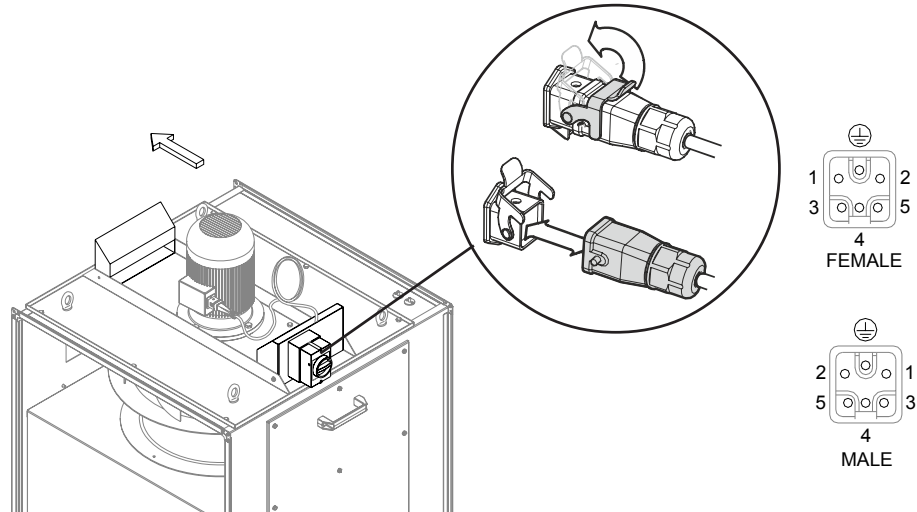

**Warning** ⚡ Ensure pins are correctly paired when connecting the plug to the isolator.

**Important** ! On weatherproof units the motor must be guarded, this is done by rotating the motor guard to the correct orientation. (Meshed edges facing the ground).

Handing Motor Guard

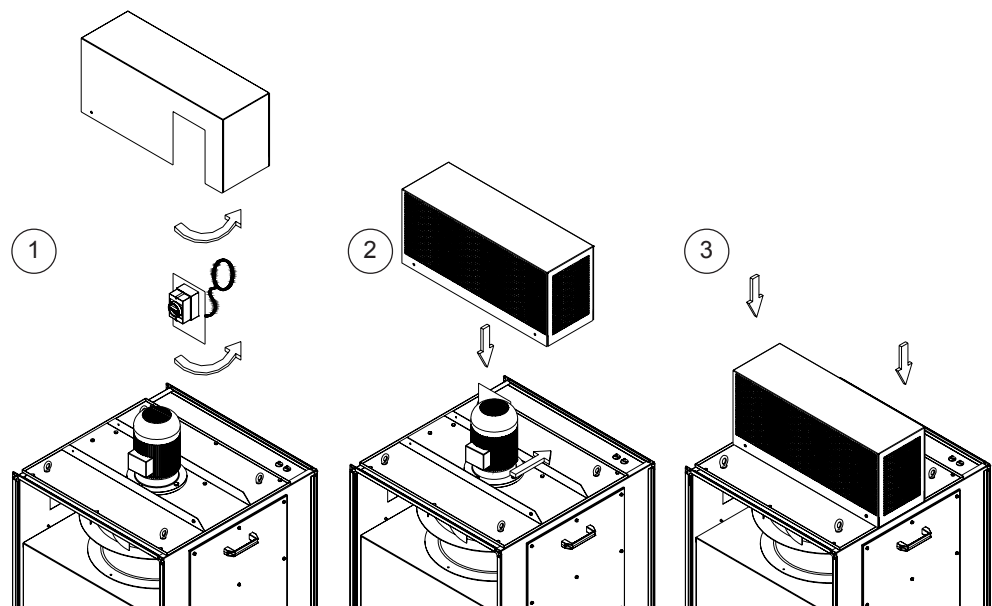



# T-Line 90 & 120 Extract Units

## Installation, Operation and Maintenance Manual

### Set-up 5

**Important**  Before starting the unit ensure the following set-up procedures are completed. Work to be carried out by a competent engineer.

**Important**  Before attempting to carry out any work on our units, all accompanying documentation including warning labels on the unit must be referenced. Should it be necessary to remove any component ensure that these are secured into position once reinstalled. It is critical that after any maintenance work has been conducted that all components removed/replaced are refitted correctly by a competent engineer.

**Warning**  Before attempting to carry out any maintenance work, investigative work, or repair work on our units, the unit **MUST BE COMPLETELY ISOLATED** from its electrical supply. Ensure a minimum of two minutes after electrical disconnection before removing access panels.

**Caution**  When accessing the unit always use the handles to ensure the access panels are handled/opened in a controlled manner so as to avoid damage to the unit or injury to personnel. This is particularly important with bottom access units.

**Important**  The impellor should rotate freely, this position is factory set. In the unlikely event of movement during transit realign the impellor with the inlet eye.

Remove the access panels and loosen the bolts holding the inlet eye in place. Align the inlet eye and impellor ensuring the inlet eye is central to the impellor and make sure gap A is constant. Hand tighten the bolts and rotate the impellor to ensure the it runs smoothly, secure into position by tightening the retaining bolts.

Impellor/Inlet Eye Alignment

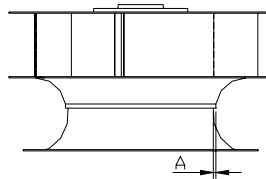

**Caution**  Ensure that the clearance gap "A" between fan and inlet eye is constant. Misalignment may cause undue wear on the impellor and inlet eye.

Impellor rotation

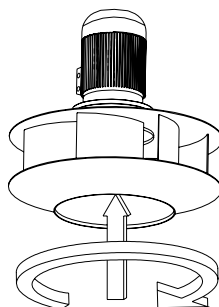

Always make sure the fan is rotating in the correct direction (anti-clockwise when viewed from the motor). Direction of airflow is indicated on the unit.

**Note:** Motor rotation can be seen on the motor cooling fan on the end of the motor. WP units may require the temporary removal of the motor cover

# T-Line 90 & 120 Extract Units

Installation, Operation and Maintenance Manual

## Set-up 5

Continued

Differential pressure tapping point

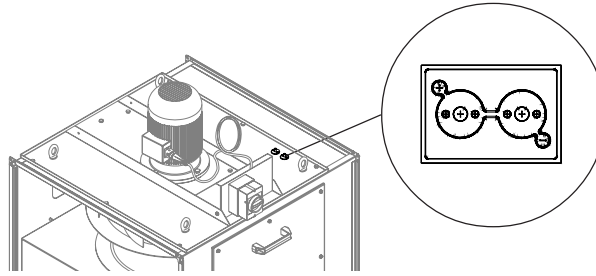

This differential pressure compares the static pressure in front of the fan inlet ring with the static pressure in the inlet ring of the narrowest point. The differential pressure between the static pressures is related to the air volume via the energy conservation rate as per the graph below. Simply read across from the pressure measurement to the appropriate fan curve and down to calculate the resultant air volume.

**For example:** Measured differential pressure: 1400Pa  
 Unit: TLL400  
 Reading from graph: 1.6  
 Air Volume: 1.6 m<sup>3</sup>/s

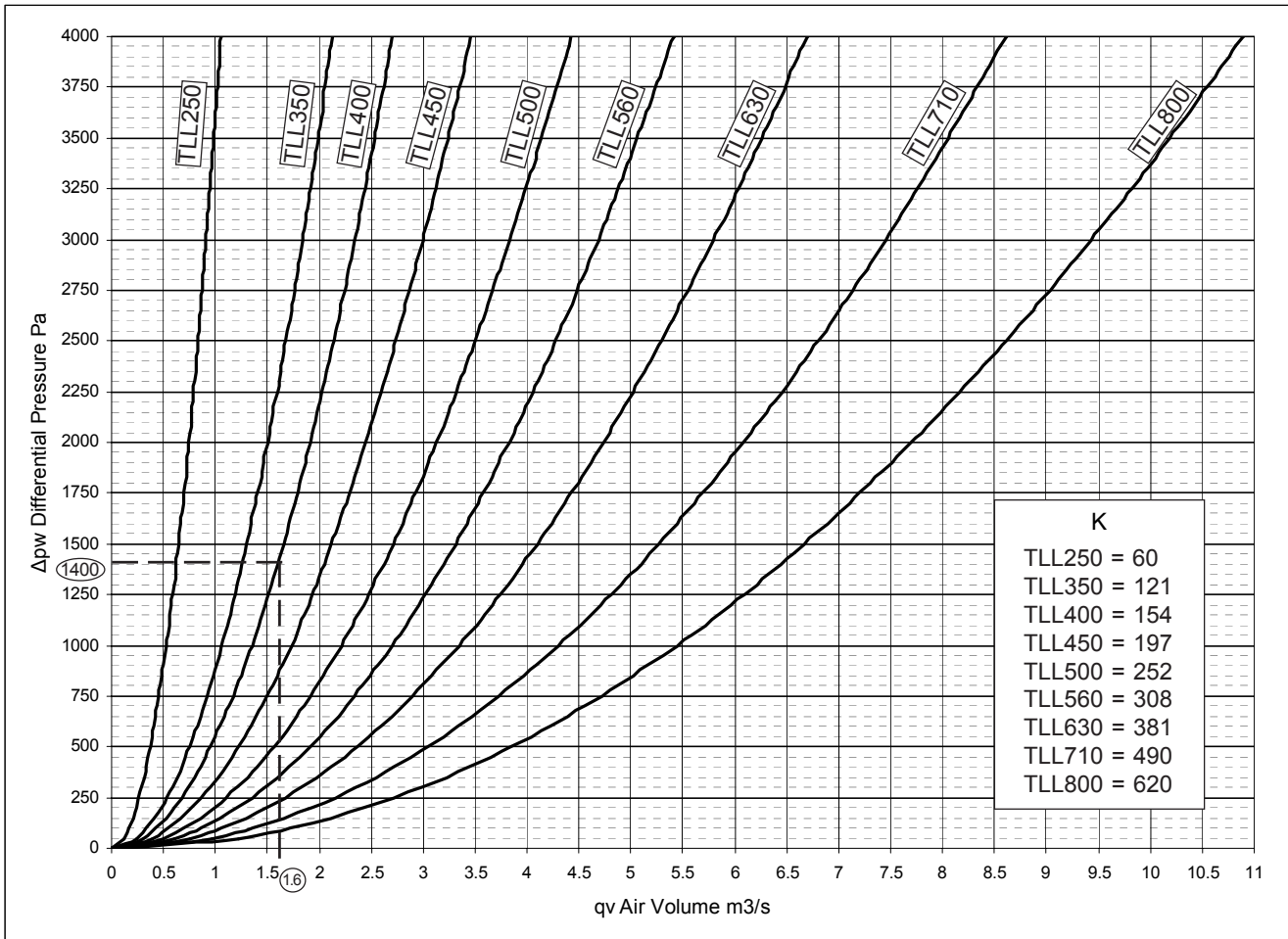

This measurement can also be expressed in the following calculation:

$$qv = (k\sqrt{\Delta pw}) / 3600$$

qv is the air volume in m<sup>3</sup>/s

k is the fan nozzle coefficient

Δpw is the measured differential pressure in Pa

**For example:** Measured differential pressure: 1400Pa  
 Unit: TLL400

$$qv = (154\sqrt{1400}) / 3600$$

$$qv = (154 \times 37.417) / 3600$$

$$qv = 5762 / 3600$$

$$qv = \text{air volume} = 1.6 \text{ m}^3/\text{s}$$

# T-Line 90 & 120 Extract Units

Installation, Operation and Maintenance Manual

## Wiring 6

**Warning**  The electrical supply must be fully isolated before attempting to complete any work on this unit. All electrical connections to any unit must be carried out in accordance with the current edition of the I.E.E Regulations and only competent electricians should be allowed to carry out any electrical work to our units.

**Important**  Motor and electrical details must be checked prior to connection to electricity supply. All motor information can be found on the unit data sheet supplied attached to the unit.

VES supply, a fitted pre-wired isolator, mains cables which should be suitably sized, refer to table, and terminated as shown on the appropriate wiring diagram, refer to pages 9-12. Ensure that suitable strain relief is fitted to the mains supply as appropriate.

### Standard 3 Phase Motor Electrical Details

3 Phase Motor Details		Motor Plate Details				Available Options	
Model	Motor Description	Motor Size (kW)	Motor Speed (rpm)	FLC (A)	SC (A)	Frequency Inverter 1ph-3ph	Frequency Inverter 3ph-3ph
TLL250/21-3*	IE1 0.37 kW 2 Pole 3 Phase	0.37	2820	1.00	4.7	●	●
TLL250/41-3*	IE1 0.25 kW 4 Pole 3 Phase	0.25	1340	0.90	2.88	●	●
TLL350/22-3*	IE2 2.2 kW 2 Pole 3 Phase	2.20	2875	4.40	30.36	●	●
TLL350/41-3*	IE1 0.37 kW 4 Pole 3 Phase	0.37	1370	1.20	3.96	●	●
TLL400/22-3*	IE2 4.0 kW 2 Pole 3 Phase	4.00	2885	7.60	57.76		●
TLL400/41-3*	IE1 0.55 kW 4 Pole 3 Phase	0.55	1400	1.60	5.76	●	●
TLL400/42-3*	IE2 0.75 kW 4 Pole 3 Phase	0.75	2845	1.80	10.44	●	●
TLL450/41-3*	IE1 1.1 kW 4 Pole 3 Phase	1.10	1400	2.70	14.04	●	●
TLL450/42-3*	IE2 1.1 kW 4 Pole 3 Phase	1.10	1435	2.40	15.84	●	●
TLL500/41-3*	IE1 1.5 kW 4 Pole 3 Phase	1.50	1400	3.60	20.52	●	●
TLL500/42-3*	IE2 1.5 kW 4 Pole 3 Phase	1.50	1435	3.30	23.10	●	●
TLL560/41-3*	IE1 3.0 kW 4 Pole 3 Phase	3.00	1425	6.80	31.28		●
TLL560/42-3*	IE2 3.0 kW 4 Pole 3 Phase	3.00	1445	6.30	44.10		●
TLL630/41-3*	IE1 5.5 kW 4 Pole 3 Phase	5.50	1430	11.30	65.54		●
TLL630/42-3*	IE2 5.5 kW 4 Pole 3 Phase	5.50	1465	11.20	70.56		●
TLL630/61-3*	IE1 2.2 kW 6 Pole 3 Phase	2.20	940	5.30	23.32	●	●
TLL630/62-3*	IE2 2.2 kW 6 Pole 3 Phase	2.20	940	5.30	23.32	●	●
TLL710/41-3*	IE1 7.5 kW 4 Pole 3 Phase	7.50	1440	15.10	102.68		●
TLL710/42-3*	IE2 7.5 kW 4 Pole 3 Phase	7.50	1460	15.30	97.92		●
TLL710/61-3*	IE1 3.0 kW 6 Pole 3 Phase	3.00	950	7.30	35.77		●
TLL710/61-3*	IE2 3.0 kW 6 Pole 3 Phase	3.00	960	7.90	33.97		●
TLL800/41-3*	IE2 18.5 kW 4 Pole 3 Phase	18.5	1477	34.50	248.4		●

# T-Line 90 & 120 Extract Units

Installation, Operation and Maintenance Manual

## Wiring 6 Continued

Warning Ensure pins are correctly paired when connecting the plug to the isolator.

### 3 Phase Direct on Line Isolator Wiring Diagram Customer connections 400v AC - 3 Phase - 50Hz

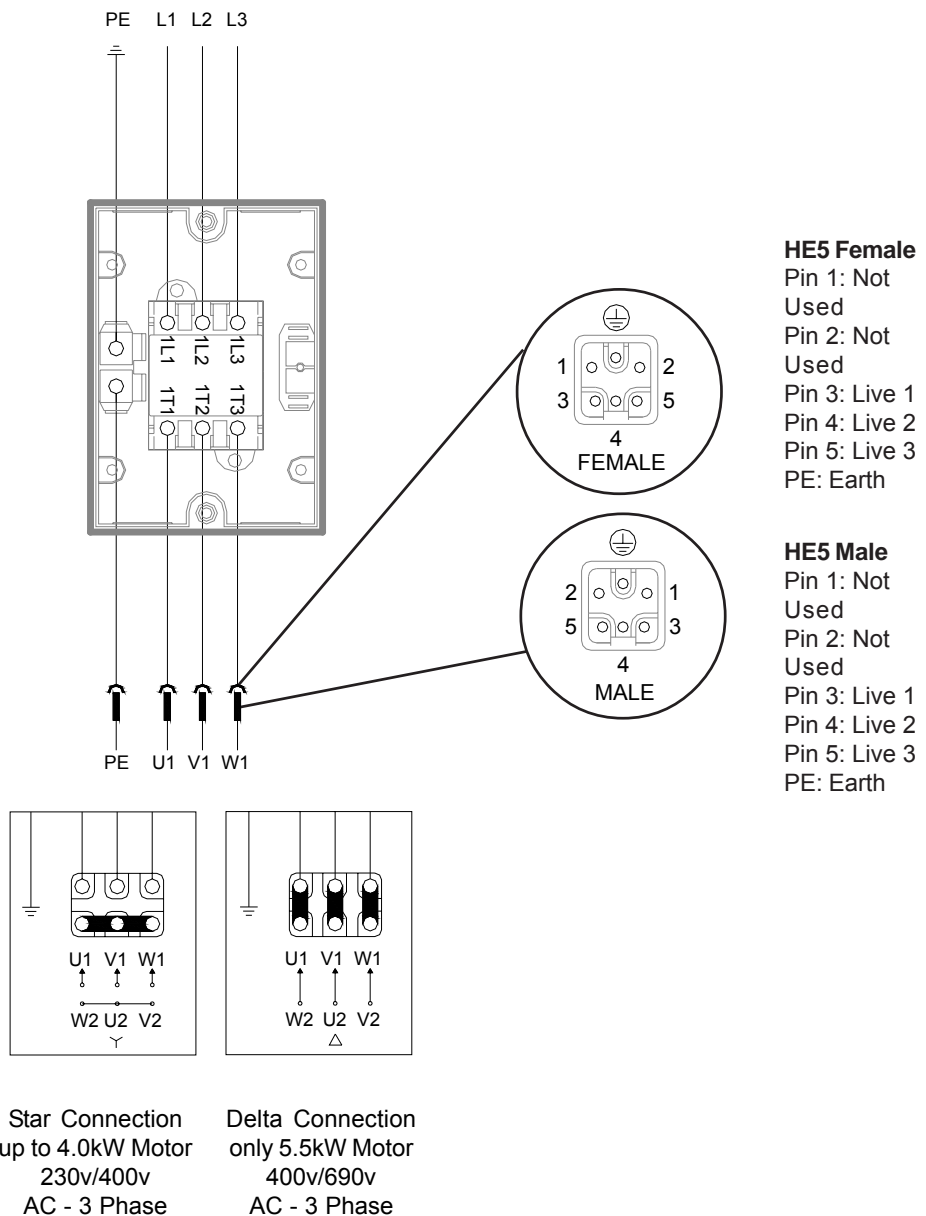

# T-Line 90 & 120 Extract Units

Installation, Operation and Maintenance Manual

## Wiring 6

Continued

Warning Ensure pins are correctly paired when connecting the plug to the isolator.

1 Ph - 3 Ph Inverter Isolator Wiring Diagram

3 Ph - 3Ph Inverter Isolator Wiring Diagram

**Customer connections**  
 230v AC - 1 Phase - 50Hz

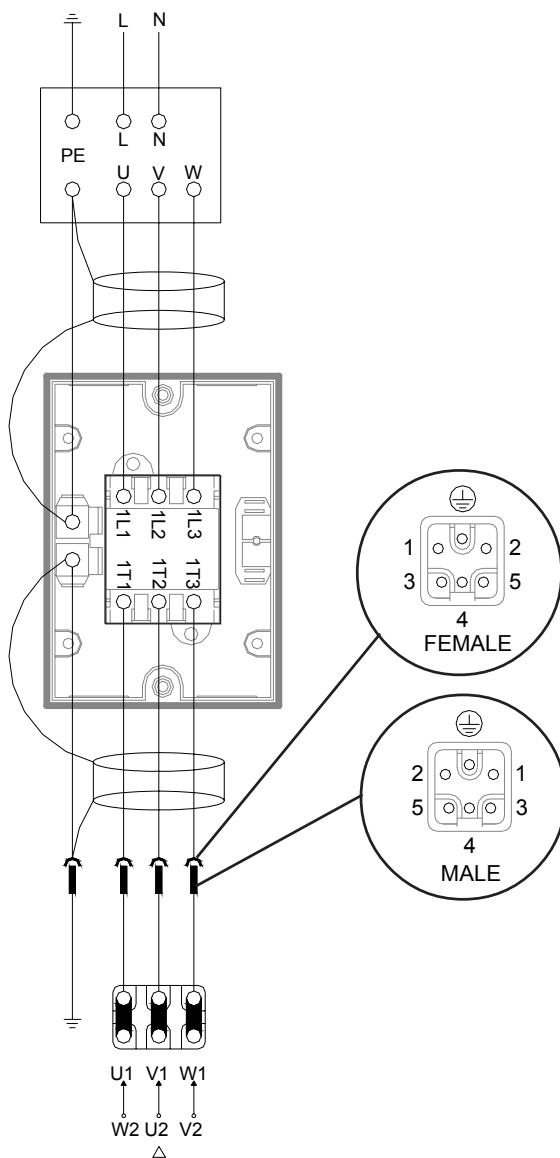

Delta Connection  
 up to 2.2kW Motor  
 230v/400v  
 AC - 3 Phase

**Customer connections**  
 400v AC - 1 Phase - 50Hz

**HE5 Female**  
 Pin 1: Not Used  
 Pin 2: Not Used  
 Pin 3: Live 1  
 Pin 4: Live 2  
 Pin 5: Live 3  
 PE: Earth

**HE5 Male**  
 Pin 1: Not Used  
 Pin 2: Not Used  
 Pin 3: Live 1  
 Pin 4: Live 2  
 Pin 5: Live 3  
 PE: Earth

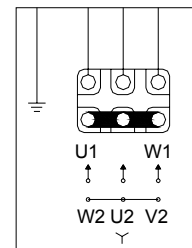
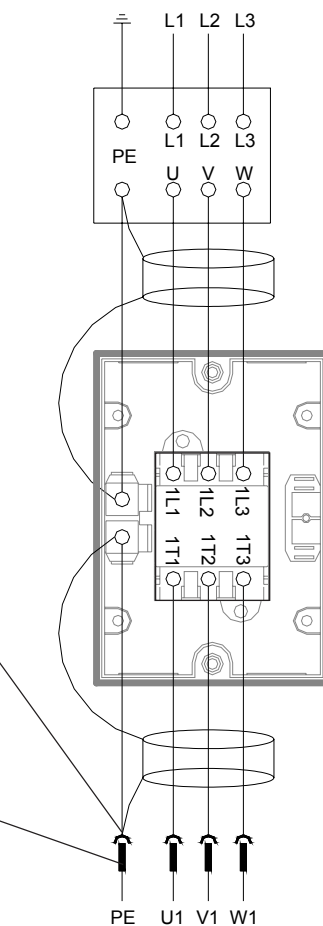

Star Connection  
 up to 4.0kW Motor  
 230v/400v  
 AC - 3 Phase

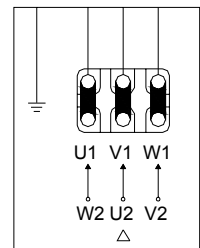

Delta Connection  
 5.5kW / 7.5kW Motor  
 400v/690v  
 AC - 3 Phase

# T-Line 90 & 120 Extract Units

Installation, Operation and Maintenance Manual

## Wiring 6

Continued

Warning Ensure pins are correctly paired when connecting the plug to the isolator.

3 Phase Star/Delta Isolator Wiring Diagram  
 Customer connections 400v AC - 3 Phase - 50Hz

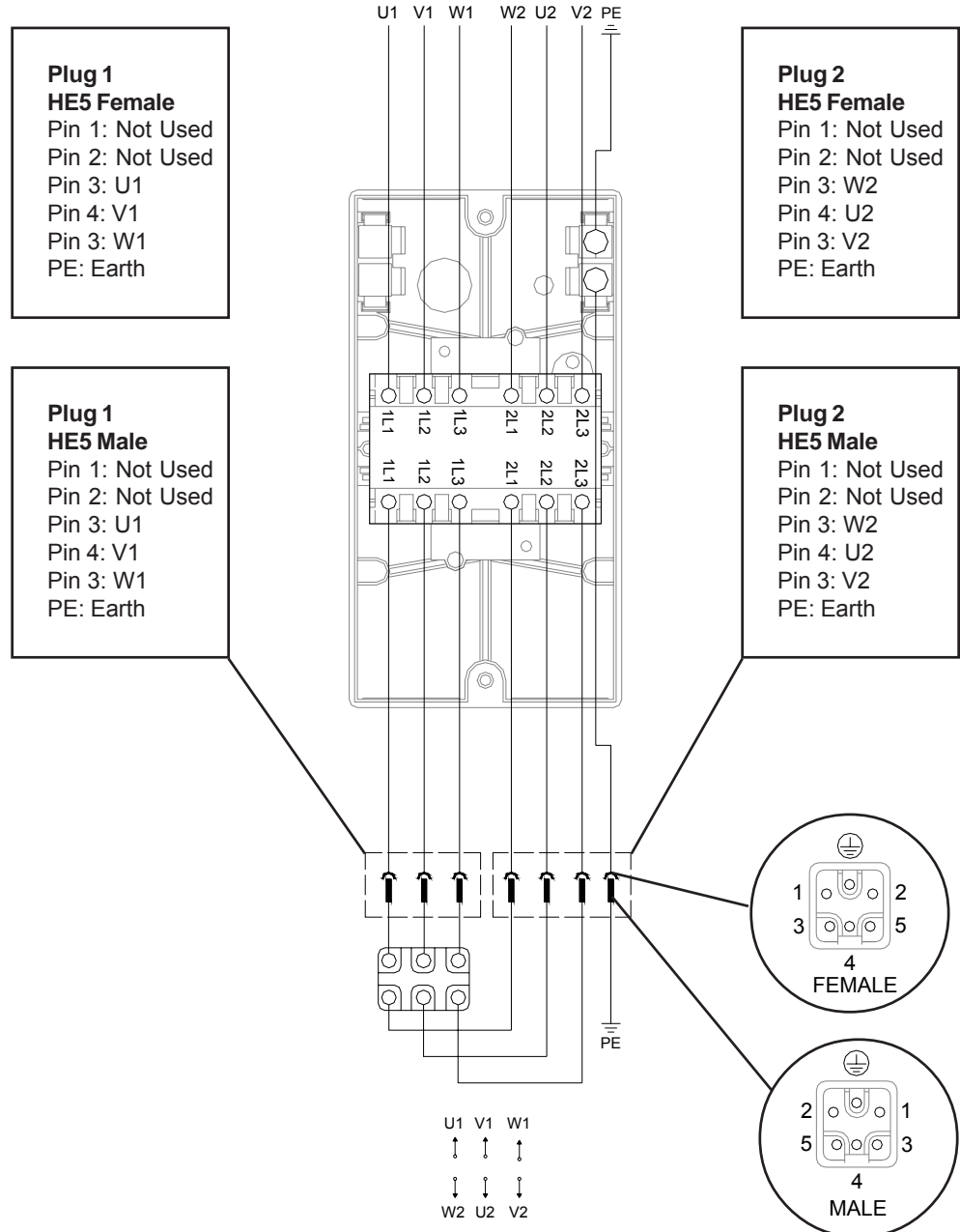

Star/Delta Connection for units with motors 7.5kW larger.

Important Motors exceeding 7.5kW are supplied wired directly back to isolator.

# T-Line 90 & 120 Extract Units

Installation, Operation and Maintenance Manual

## Wiring 6 Continued

Warning Ensure pins are correctly paired when connecting the plug to the isolator.

3 Phase Star/Delta Isolator Wiring Diagram  
 Customer connections 400v AC - 3 Phase - 50Hz

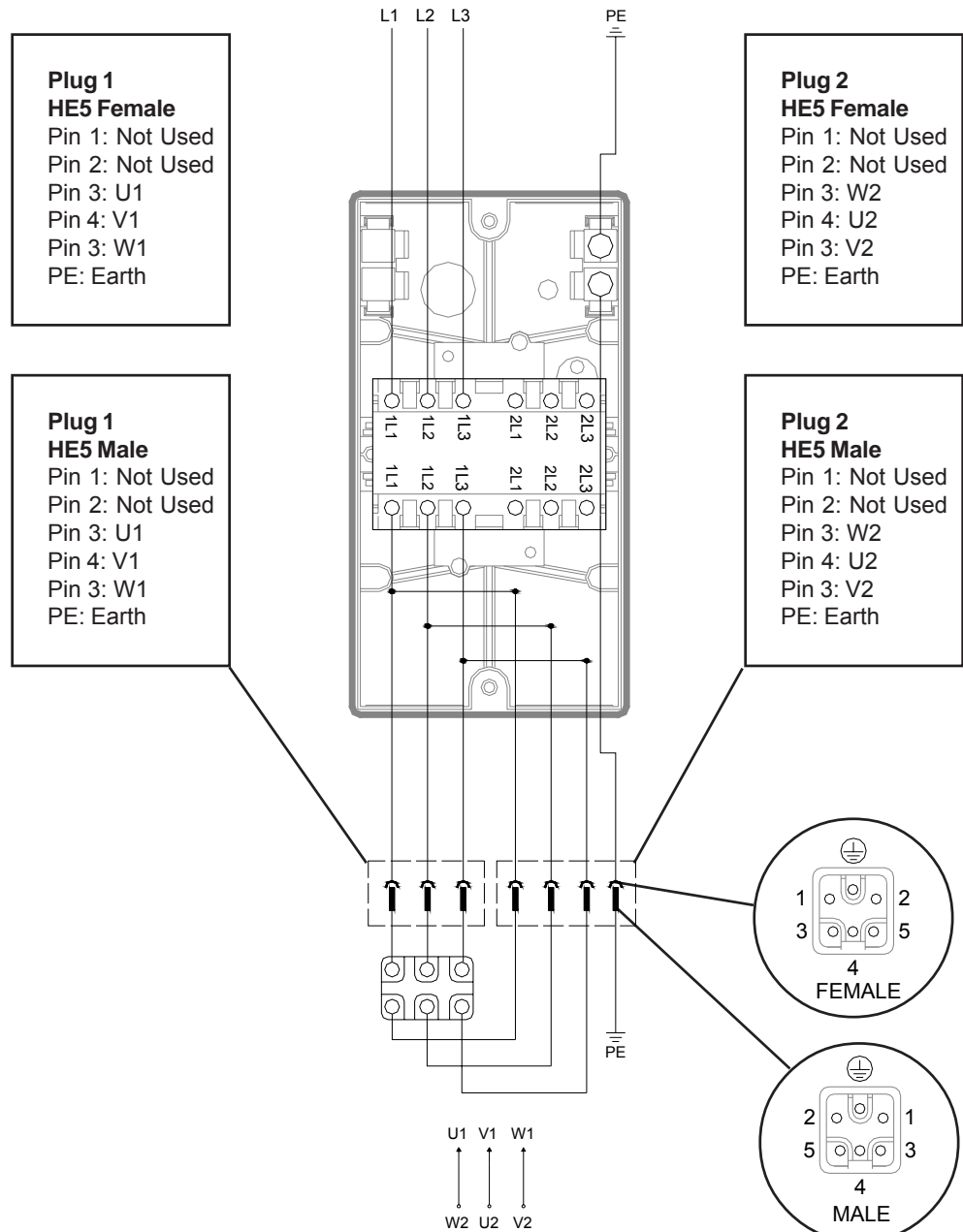

Important Motors exceeding 7.5kW are supplied wired directly back to isolator.

# T-Line 90 & 120 Extract Units

Installation, Operation and Maintenance Manual

## Wiring 6

Continued

Standard 1 Phase Motor  
 Electrical Details

1 Phase Motor Details		Motor Plate Details			
Model	Motor Description	Motor Size (kW)	Motor Speed (rpm)	FLC (A)	SC (A)
TLL250/21-1*	IE1 0.37 kW 2 Pole 1 Phase	0.37	2780	3.10	9.61
TLL250/41-1*	IE1 0.25 kW 4 Pole 1 Phase	0.25	1270	2.50	6.00
TLL350/21-1*	IE1 2.2 kW 2 Pole 1 Phase	2.20	2770	14.60	62.78
TLL350/41-1*	IE1 0.37 kW 4 Pole 1 Phase	0.37	1370	2.80	8.12
TLL400/41-1*	IE1 0.55 kW 4 Pole 1 Phase	0.55	1390	4.00	12.80
TLL450/41-1*	IE1 1.1 kW 4 Pole 1 Phase	1.10	1415	7.40	26.64
TLL500/41-1*	IE1 1.5 kW 4 Pole 1 Phase	1.50	1430	9.00	38.70

Speed Controller not available for single phase motors

Warning Ensure pins are correctly paired when connecting the plug to the isolator.

### 1 Phase Isolator Wiring Diagram

Customer connections 2300v AC - 1 Phase - 50Hz

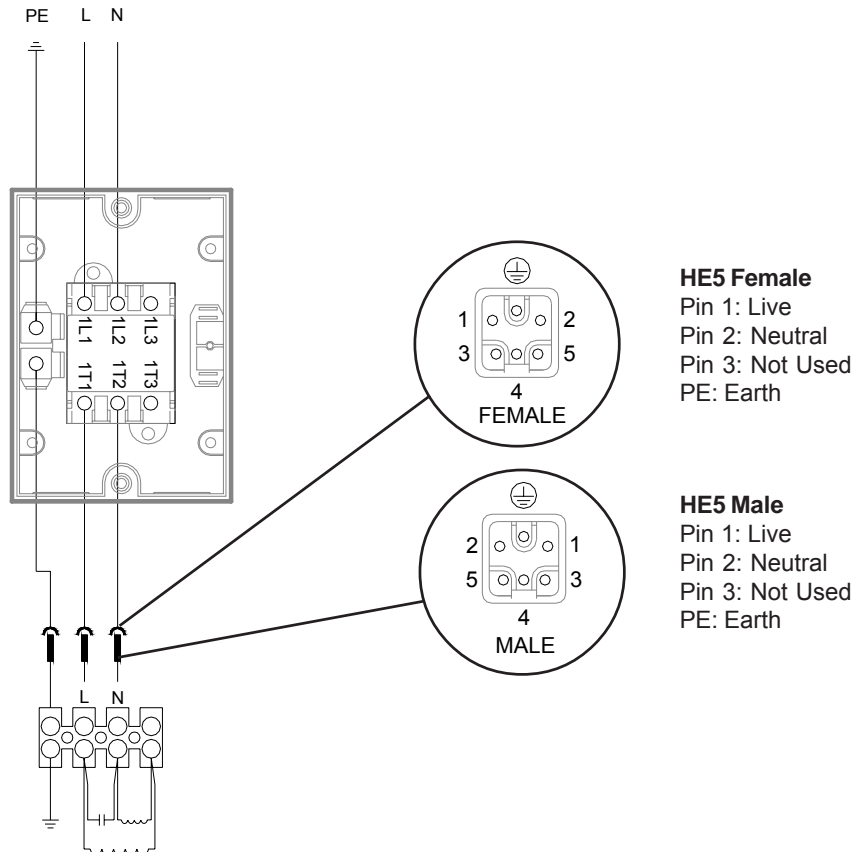

# T-Line 90 & 120 Extract Units

Installation, Operation and Maintenance Manual

## Controls 7

**Warning**  The electrical supply must be fully isolated before attempting to complete any work on this unit. All electrical connections, to any unit, must be carried out in accordance with the current edition of the I.E.E Regulations, and only competent Electricians should be allowed to carry out any electrical work to our units.

### Introduction 7.1

VES offer a range of controls suited for the control of selected motors used on the T-Line range. Three phase speed controllers use frequency drivers that offer 0-100% stepless control from a wide range of input signals. Inverters are genuine energy saving devices, and under the Energy Technology List ECA Scheme, the client can claim back 100% tax relief for inverters in the first year. See [www.eca.gov.uk](http://www.eca.gov.uk) for details.

**Note:** Inverters can cause interference to nearby electronic equipment and must be installed correctly to avoid this happening.

#### IP21 Inverter

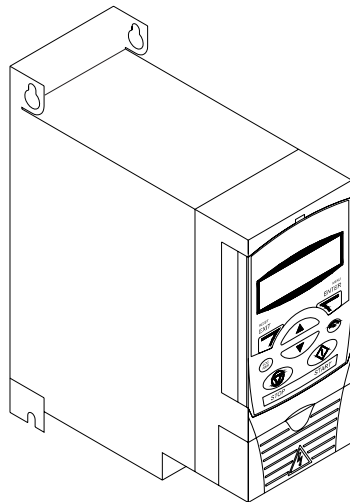

#### IP21 Inverter Specification

Low cost inverter with IP21 enclosure. Suitable for internal location.

- Sized to match T-Line 3 phase motor.
- Complete with operational keypad.
- IP21/NEMA1 protection for indoor use.
- On/off control at inverter pad with built-in pot for easy adjustment, and BMS control. Remote pot control available (CFSC1).

#### IP54 Inverter

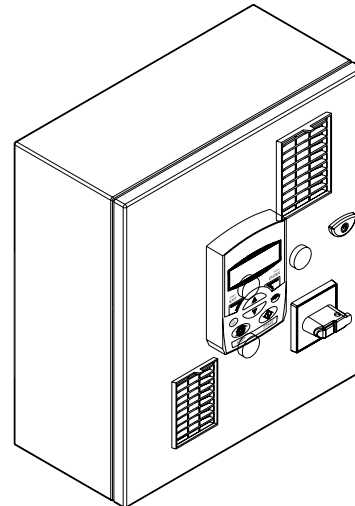

#### IP54 Inverter Specification

Inverter with comprehensive range of functions and IP54 enclosure.

- Sized to match T-Line 3 phase motor.
- Complete with operational keypad.
- Optional advanced keypad with built-in time clock.
- IP54 protection for indoor or external use.
- BMS control, remote pot, temperature, constant pressure, humidity and CO2/ VOC control.
- Main isolating switch with lockable handle.
- Panel live indicator.
- Damper control.
- Volt free run and trip indication.
- Connections for motor thermal cutout safety interlock.
- Easy customer installation.

# T-Line 90 & 120 Extract Units

Installation, Operation and Maintenance Manual

**Controls 7**  
 Continued  
**7.2 Option**  
**Operation :**

Layout:



**Important** In order to proceed with electrical connection and programming you must firstly unscrew the hinged cover, this should be closed carefully after completion!

	<b>D</b>	LC-Display Moon symbol = Adjustment for Setpoint 2 active ! = Exceeding measuring range
	<b>+Ub / GND</b>	Supply voltage
	<b>A / GND</b>	Output signal 0 - 10 V
	<b>1 / 2</b>	Voltage input for switch over Setpoint 1 / Setpoint 2
		Pressure connections
	<b>+</b>	"Plus"- connection in area with higher pressure
	<b>-</b>	"Minus"- connection in area with lower pressure

**Button Operation:**

Multifunction LC display and internal keyboard

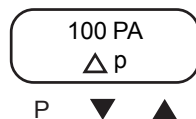

- P Program key and open menu
- ▲ Menu selection, to reduce value
- ▼ Menu selection, to increase value
- ▼+▲ ESC-key combination, Escape = to leave menu

# T-Line 90 & 120 Extract Units

Installation, Operation and Maintenance Manual

## Controls 7

Continued

### 7.3 Description:

#### 7.3.1

#### Applications:

- Pressure and volume control for ventilation systems.
- The sensor comes with a membrane system suitable for measuring differential or negative pressure of non-aggressive gas. The differential pressure is measured using a spring supported silicone membrane. The sensor works when the pressure at the "Plus" - connection exceeds the pressure at the "Minus" -connection. Changes in position of the membrane are detected by a differential transformer and are converted into an output signal of 0 - 10 V by an electronics unit. There are 3 types of device to cover the pressure range from 50 Pa to 6000 Pa. With four calibrated measuring ranges programmable for each type.

Depending on the programmed Mode the device can be used as sensor or as a control module for pressure or volume.

- When used as a pressure sensor the device supplies an output signal (0 - 10 V) proportional to the measuring range.
- When used as a air volume sensor the device supplies an output signal (0 - 10V) proportional to the air volume measuring range (INFO/Range qV). This is used in combination with centrifugal fans and a ring conduit in the inlet duct. The controller calculates the air volume of the fan from the "K-Factor" and pressure differential between the suction side and inlet duct.
- When used as a control module for pressure or volume, the purpose of the device is to reach and maintain the target value set. To accomplish this, the measured actual value (sensor value) is compared with the adjusted target value, and the controlled value is deduced from this. Controlled output (0 - 10 V) e.g for activating a speed controller for fans or an EC-fan directly.

### 7.4 Mounting and Installation:

Caution  The following points must be complied with during the mechanical installation to avoid causing faults in the device due to assembly errors or environmental influences.

#### 7.4.1 General notes:

- Before installation remove the device from the packaging and check for any possible shipping damage!
- Assemble the device on a clean and stable base. Do not distort during assembly! Use the appropriate mounting devices for proper installation of the unit!
- If the controller is mounted onto a lightweight wall, there must be no overly high vibrations or shock loads. Any banging shut of doors integrated into these lightweight walls, can result in extremely high shock loads. Therefore, we would advise you to decouple the device from the wall.
- Do not allow drilling chips, screws and other foreign bodies to reach the device interior!
- **Accuracy of the pressure sensor depends upon positioning, therefore the controller must be mounted vertically and if possible in a vibration free place (cable inlet and pressure connections need to be at the base).**
- The pressure line's should be connected with plastic-hose (interior use), with an inside diameter of 4mm.

#### 7.4.2 Outdoor Installation:

Outdoor installation is possible in areas with a temperature of up to -10°C and a constant electrical supply to the controller. The controller once mounted must be protected from the effects of the weather as much as possible, including protection from direct sunlight!



# T-Line 90 & 120 Extract Units

Installation, Operation and Maintenance Manual

## Controls 7

Continued

### 7.4 Mounting and Installation continued:

<p>Caution </p>	<ul style="list-style-type: none"> <li>• A room controller must be mounted in a clean, dry indoor place, if externally mounted the unit must be protected from the effects of weather as much as possible and must not be exposed to water.</li> <li>• Never clean electrical equipment with water or similar liquids.</li> </ul>
<p>Important </p>	<ul style="list-style-type: none"> <li>• Comply with local regulations to wire, fuse, and earth the unit.</li> <li>• The power supply line must have an external fuse circuit breaker with a rated current to meet the required unit full load current.</li> </ul>
<p>Warning </p>	<ul style="list-style-type: none"> <li>• Work on electrical components may only be carried out by trained electricians in accordance with electrical engineering regulations.</li> <li>• The programming of the equipment needs to take place with a live electrical supply/voltage. The cover needs to be open and voltage set for change-over Setpoint 1/2. Use power supplies which guarantee reliable electrical isolation of the operating voltage as per IEC/DIN EN 60204-1. Consider also the general requirements for PELV circuits in accordance with IEC/DIN EN 60204-1.</li> <li>• Inspect electrical equipment periodically: retighten connections - immediately replace damaged lines and cables.</li> <li>• Disconnect power supply before removing the controller from the mounting plate.</li> </ul>

#### 7.4.3 EMC-compatible control lines:

Attention must be paid to ensure a sufficient distance from powerlines and motor wires to prevent interferences. The control cable may not be longer than 30 m. Screened control cables must be used when the cable length is longer than 20m!

#### 7.4.4 Connection Voltage supply:

Connection Voltage supply at terminals: "+Ub" and "GND". Mains voltage must lie within the allowable tolerance specifications (see Technical data and have a nameplate affixed to the side).

#### 7.4.5 Output voltage 0-10V:

Connection to terminal "A" - "GND" ( $I_{max} 0.3mA$ ). It is not permissible to connect outputs of several devices to each other!

#### 7.4.6 Input for switch over Setpoints:

Via voltage at terminals "1" and "2" (10...24 V DC) a switch over between Setpoint 1 and Setpoint 2 is possible (note polarity, see connection diagram).

100 PA  
Setpoint 1

No voltage at terminal "1" and "2" = adjustment for Setpoint 1 active.

80 PA C  
Setpoint 2

Voltage at terminals "1" and "2" = adjustment for setpoint 2 active.

The active Setpoint is indicated in the menu INFO, a active "Setpoint 2" is signalled by the moon symbol. ☾

# T-Line 90 & 120 Extract Units

Installation, Operation and Maintenance Manual

## Controls 7

Continued

### 7.5 Menu Operation:

#### 7.5.1 Select operation mode:

Important  Simple set up is possible by selecting the preprogrammed mode of operation. This determines the basic function of the device, as factory set **4.01**

Mode	Function
<b>4.00</b>	Pressure sensor output 0..10 V proportional to measuring range
<b>4.01</b>	Pressure controller (PID): output 0...10 V depending on adjusted Setpoint and measured actual value.
<b>5.00</b>	Air volume sensor: Output 0...10 V proportional to measuring range (depending on setting for K-factor)
<b>5.01</b>	Air volume controller(PID): Output 0...10 V depending on adjusted Setpoint and measured actual value.

#### 7.5.2 Menu Structure:

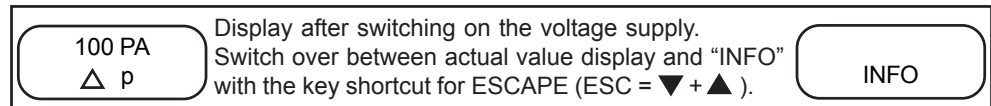

#### Example for Mode **4.01** (Factory setting)

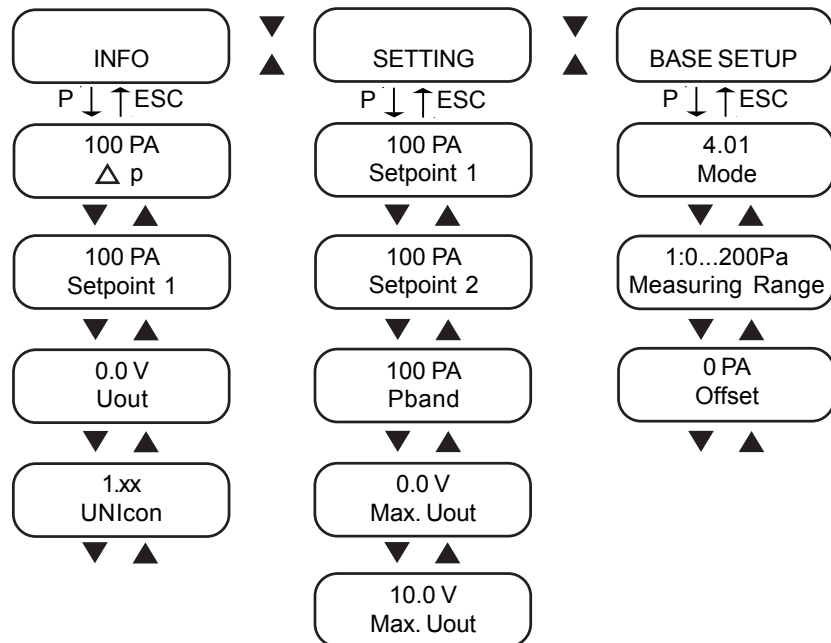

Selection of the menu group (e.g. BASE SETUP) to the right through the ▼-key, to the left through the ▲-key.

You can go to the menu items in the menu groups (e.g. mode) by using the P key. Use the arrow keys to move up and down within the menu group.

To make adjustments, press the P key after selecting the menu item. If the previously set value starts to flash, it can be adjusted with the ▼ + ▲ keys and then saved with the P key. To exit the menu without making changes, use the "ESC" short-key, i.e. you wish to keep the original values.

# T-Line 90 & 120 Extract Units

Installation, Operation and Maintenance Manual

## Controls 7

Continued

### 7.5.2 Menu structure continued:

Reprogramming Mode **4.01** to **5.00** in "BASE SETUP"

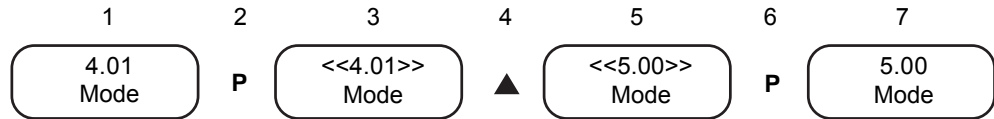

### 7.6 Programming:

#### 7.6.1 :

Pressure sensor **4.00** /pressure controller **4.01**

Base setup **4.00** and **4.01**

BASE SETUP	BASE SETUP
4.01 Mode	Mode Setting of mode e.g. <b>4.01</b>
0...200 Pa Measuring Range	Measuring Range Setting of desired pressure measuring range Setting range: depending upon device type (see Technical data) Factory setting: respective max. measuring range
0 Pa Offset	Offset Sensor calibration with calibrated comparison device Setting range: +100...+100Pa Factory setting: 0 Pa

#### 7.6.2 :

Setting for operation, only **4.01**

SETTING	SETTING
100 Pa Setpoint 1	Setpoint 1 Setting range: Setpoint 1:0... 100% sensor measuring range Factory setting: 50% sensor measuring range
100 Pa Setpoint 2	Setpoint 2 Setting "Setpoint 2" e.g reduced value night operation. Switch over Setpoint 1/2 by external voltage at terminals 1/2.
100 Pa Pband	Pband small control range = short control times big control range = longer control times and (higher controller stability) Setting range Pband: 0...100% sensor measuring range Factory setting: 50% sensor measuring range
0.0 V Min.Uout	Min. Uout Setting range minimal output voltage (basic speed): 0.0 V...10.0 V (setting takes priority over "Max. Uout") Factory setting: 0.0 V
10.0 V Max.Uout	Max. Uout Setting range maximal output voltage (speed limiter): 10.0 V...0.0 V Factory setting: 10.0 V

# T-Line 90 & 120 Extract Units

Installation, Operation and Maintenance Manual

## Controls ?

Continued

7.6 Programming:

7.6.3 :

**Air volume sensor 5.00 /air volume controller 5.01**

**Base setup 5.00 and 5.01**

BASE SETUP	BASE SETUP
5.01 Mode	Mode Setting of mode e.g. <b>5.01</b>
0...200 Pa Measuring Range	Measuring Range Setting of desired pressure measuring range Setting range: depending on device type (see Technical data) Factory setting: respective max. measuring range
75 K-Factor	K-Factor Input of the "K-Factor" dependant on the fan (inlet duct). Setting range: depending on measuring range of sensor Factory setting: 75
0m³/h Offset	Offset Sensor calibration with calibrated comparison device. Setting range: -1000...+1000m³/h Factory setting: 0m³/h

Air volume measuring range [m³/h] depends on selected measuring range of pressure sensor [Pa] and selected K-Factor. In menu INFO display for Range qV. Where the maximum K-Factor input are selected the maximum measuring range of approx. 65000m³/h could theoretically be achieved.

The maximal adjustable K-Factor depends on the selected measuring range of the pressure sensor [Pa].											
Measuring Range [Pa]	50	100	150	200	300	500	1000	2000	3000	4000	6000
Max. K-Factor	4633	3276	2675	2316	1891	1465	1036	732	598	518	423

7.6.4 :

**Settings for operation, only 5.01**

SETTING	SETTING
530 m³/h Setpoint 1	Setpoint 1 Setting range Setpoint 1: 0... Max. Range qV Factory settings: 50% Max. Range qV
530 m³/h Setpoint 2	Setpoint 2 Setting "Setpoint 2" e.g reduced value for night operation. Switch over Setpoint 1/2 by external voltage to terminals 1/2.
530 m³/h Pband	Pband small control range = short control times big control range = longer control times and (higher controller stability) Adjustable Pband: 0... Max. Range qV Factory setting: 50 % Max. Range qV
0.0 V Min. Uout	Min. Uout Setting range minimal output voltage (basic speed): 0.0 V... 10.0 V (setting takes priority over "Max, Uout") Factory setting: 0.0 V
10.0 V Max. Uout	Max. Uout Setting range maximal output voltage (speed limiter): 10.0 V... 0.0 V Factory setting: 10.0 V

# T-Line 90 & 120 Extract Units

Installation, Operation and Maintenance Manual

## Controls 7

Continued

7.7 Connection  
 Diagram:

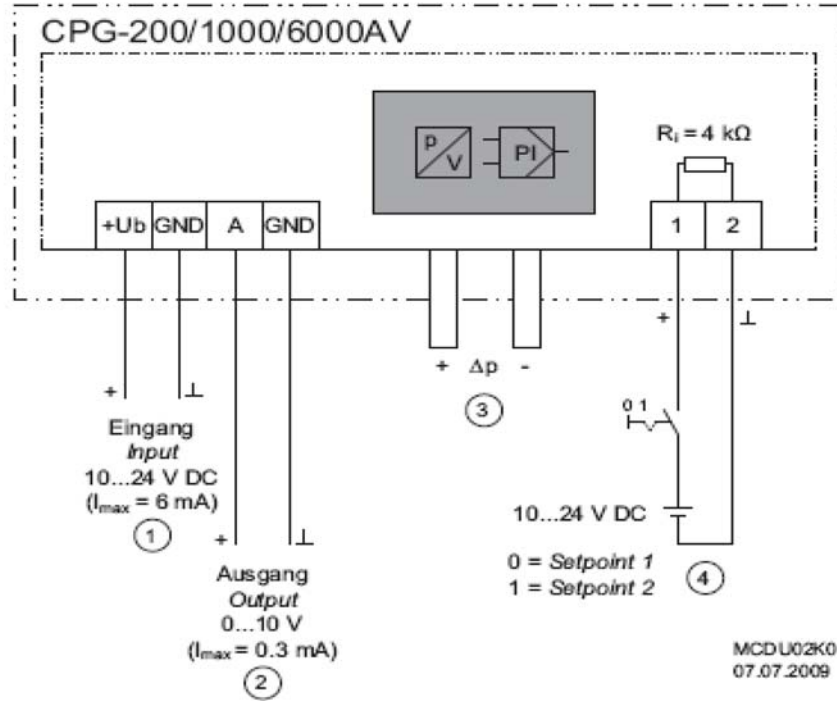

7.8 Waste disposal/  
 recycling:

Disposal must be carried out professionally and in an environmentally friendly way and in accordance with legal stipulations.

## T-Line 90 & 120 Extract Units

Installation, Operation and Maintenance Manual

### Installation and Commissioning Flow Chart 8

Warning  The electrical supply must be fully isolated before attempting to complete any work on this unit All electrical connections to any unit must be carried out in accordance with the current edition of the I.E.E Regulations and only competent Electricians should be allowed to carry out any electrical work to our units.

#### Task

- 1 Identify the frame size of your drive: R0.R4
- 2 Plan the installation: select the cables, etc.  
Check the ambient conditions, ratings and required cooling air flow.
- 3 Unpack and check the drive.
- 4 If the drive will be connected to an IT (ungrounded) or corner grounded system, check that the internal EMC filter is not connected.
- 5 Install the drive on a wall or in a cabinet.
- 6 Route the cables.
- 7 Check the insulation of the input cable and the motor, and the motor cable.
- 8 Connect the power cables.
- 9 Connect the control cables.
- 10 Check the installation.
- 11 Commission the drive.

# T-Line 90 & 120 Extract Units

Installation, Operation and Maintenance Manual

## Basic Control 9 Panel



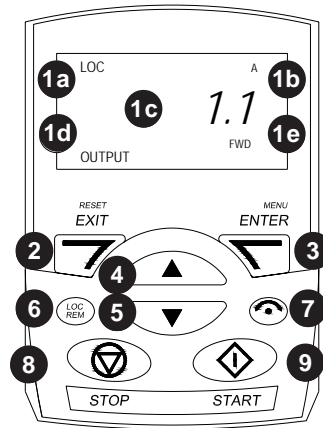

Overview

The following table summarizes the key functions and displays on the Basic Control Panel.



- 1 LCD display. Divided into five areas:
  - a. Upper left . Control location:  
LOC: drive control is local, that is, from the control panel  
REM: drive control is remote, such as the drive I/O or fieldbus.
  - b. Upper right . Unit of the displayed value.
  - c. Center . Variable; in general, shows parameter and signal values, menus or lists. Shows also fault and alarm codes.
  - d. Lower left and center . Panel operation state:  
OUTPUT: Output mode  
PAR: Parameter mode  
MENU: Main menu.  
**FAULT** Fault mode.
  - e. Lower right . Indicators:  
FWD (forward) / REV (reverse): direction of the motor rotation  
Flashing slowly: stopped  
Flashing rapidly: running, not at setpoint  
Steady: running, at setpoint  
**SET** Displayed value can be modified (in the Parameter and Reference modes).
- 2 RESET/EXIT. Exits to the next higher menu level without saving changed values. Resets faults in the Output and Fault modes.
- 3 MENU/ENTER. Enters deeper into menu level. In the Parameter mode, saves the displayed value as the new setting.
- 4 Up.
  - Scrolls up through a menu or list.
  - Increases a value if a parameter is selected.
  - Increases the reference value in the Reference mode.
 Holding the key down changes the value faster.
- 5 Down.
  - Scrolls down through a menu or list.
  - Decreases a value if a parameter is selected.
  - Decreases the reference value in the Reference mode.
 Holding the key down changes the value faster.
- 6 LOC/REM. Changes between local and remote control of the drive.
- 7 DIR. Changes the direction of the motor rotation.
- 8 STOP. Stops the drive in local control.
- 9 START. Starts the drive in local control.

### Operation

You operate the control panel with the help of menus and keys. You select an option, e.g. operation mode or parameter, by scrolling the  and  arrow keys until the option is visible in the display and then pressing the  key. With the  key, you return to the previous operation level without saving the made changes. The Basic Control Panel has five panel modes: Output, Reference, Parameter, Copy and Fault. The operation in the first four modes is described in this chapter. When a fault or alarm occurs, the panel goes automatically to the Fault mode showing the fault or alarm code. You can reset the fault or alarm in the Output or Fault mode. After the power is switched on, the panel is in the Output mode, where you can start, stop, change the direction, switch between local and remote control and monitor up to three actual values (one at a time). To do other tasks, go first to the Main menu and select the appropriate mode.

# T-Line 90 & 120 Extract Units

Installation, Operation and Maintenance Manual

## Terminal 10 connections

**Warning** The electrical supply must be fully isolated before attempting to complete any work on this unit All electrical connections to any unit must be carried out in accordance with the current edition of the I.E.E Regulations and only competent Electricians should be allowed to carry out any electrical work to our units.

Inverter Wiring Diagram

For illustration purposes only

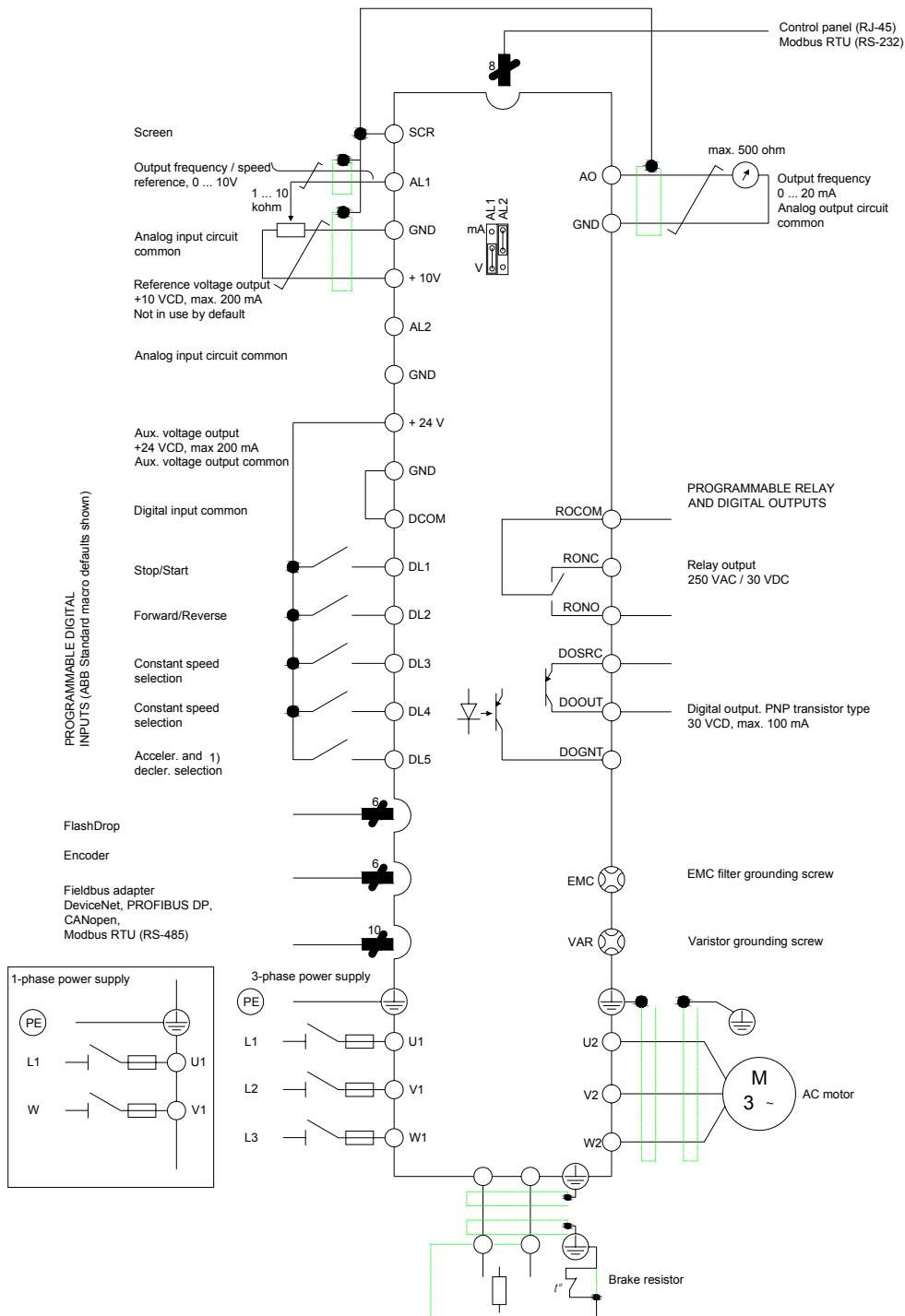

# T-Line 90 & 120 Extract Units

Installation, Operation and Maintenance Manual

## Installation 11 Checklist

Mechanical Installation

- The ambient operating conditions are allowed.
- The drive is fixed properly on an even vertical non-flammable wall.
- The cooling air will flow freely.

Electrical Installation

The motor and the driven equipment are ready for start.

For ungrounded and corner grounded systems: The internal EMC filter is disconnected (EMC screw removed).

- The capacitors are reformed if the drive has been stored over two years.
- The drive is grounded properly.
- The input power voltage matches the drive nominal input voltage.
- The input power connections at U1, V1 and W1 are OK and tightened with the correct torque.
- Appropriate input power fuses and disconnecter are installed.
- The motor connections at U2, V2 and W2 are OK and tightened with the correct torque.
- The motor cable is routed away from other cables.
- The external control (I/O) connections are OK.
- The input power voltage cannot be applied to the output of the drive (with a bypass connection).
- Terminal cover and, for NEMA 1, hood and connection box, are in place.

Go through the checklist below together with another person.

## Start- Up12

Safety

Warning  The start-up may only be carried out by a qualified electrician.

Caution  The drive will start up automatically at power up if the external run command is on.

- Check the installation. Refer to checklists above
- Check that the starting of the motor does not cause any danger. De-couple the driven machine if:
  - There is a risk of damage in case of incorrect direction of rotation, or
  - An ID Run needs to be performed during the drive start-up. ID Run is essential only in applications that require the ultimate in motor control accuracy.

Power Up

- Apply input power.

The Basic Control Panel powers up into the Output mode. The Assistant Control Panel asks if you want to run the Startup Assistant. If you press , the Start-up Assistant is not run, and you can continue with manual start-up in a similar manner as described below for the Basic Control Panel.

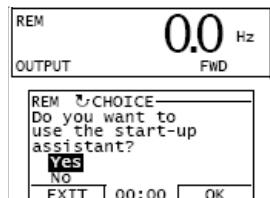

# T-Line 90 & 120 Extract Units

Installation, Operation and Maintenance Manual

## Start-Up12















Continued

### MANUAL ENTRY OF START - UP DATA (parameter group 99)

- If you have an Assistant Control Panel, select the language (the Basic Control Panel does not support languages).

The general parameter setting procedure is described below for the Basic Control Panel.

The general parameter setting procedure:

1. To go to the Main menu, press  if the bottom line shows OUTPUT; otherwise press  repeatedly until you see MENU at the bottom.
2. Press keys  /  until you see "PAR" and press .
3. Find the appropriate parameter group with keys  /  and press .
4. Find the appropriate parameter in the group with keys  / .
5. Press and hold  for about two seconds until the parameter value is shown with **SET** under the value.
6. Change the value with keys  / . The value changes faster while you keep the  key pressed down.
7. Save the parameter value by pressing .

- Select the application macro (parameter 9902). The general parameter setting procedure is given above. The default value 1 (ABB STANDARD) is suitable in most cases.

- Select the motor control mode (parameter 9904). 1 (VECTOR:SPEED) is suitable in most cases. 2 (VECTOR:TORQ) is suitable for torque control applications. 3 (SCALAR:FREQ) is recommended

- for multimotor drives when the number of the motors connected to the drive is variable
- when the nominal current of the motor is less than 20% of the nominal current of the drive
- when the drive is used for test purposes with no motor connected.

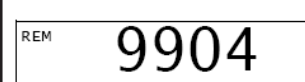
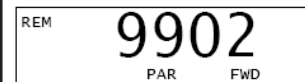
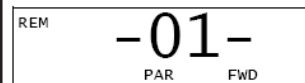

# T-Line 90 & 120 Extract Units

Installation, Operation and Maintenance Manual

## Start-Up 12 Continued

### MANUAL ENTRY OF START - UP DATA (PARAMETER GROUP 99) - CONTINUED

- Enter the motor data from the motor nameplate:

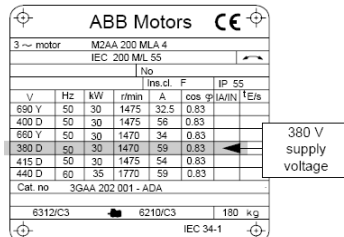

V	Hz	kW	r/min	A	cos φ	η	IE/ff
690 V	50	30	1475	32.5	0.83		
400 D	50	30	1475	58	0.83		
690 V	50	30	1470	34	0.83		
380 D	50	30	1470	59	0.83		
415 D	50	30	1475	54	0.83		
440 D	60	35	1770	59	0.83		

**Note:** Set the motor data to exactly the same value as on the motor name plate. For example, if the motor nominal speed is 1440 rpm on the name plate, setting the value of parameter 9908 MOTOR NOM SPEED to 1500 rpm results in the wrong operation of the drive.

- motor nominal voltage (parameter 9905)
- motor nominal current (parameter 9906)  
Allowed range: 0.2.2.0 · I<sub>2N</sub> A
- motor nominal frequency (parameter 9907)
- motor nominal speed (parameter 9908)
- motor nominal power (parameter 9909)

REM	9905	PAR	FWD
REM	9906	PAR	FWD
REM	9907	PAR	FWD
REM	9908	PAR	FWD
REM	9909	PAR	FWD

- Select the motor identification method (parameter 9910).

The default value 0 (OFF/IDMAGN) using the identification magnetization is suitable for most applications. It is applied in this basic start-up procedure. Note however that this requires that:

- parameter 9904 is set to 1 (VECTOR: SPEED) or 2 (VECTOR: TORQ)
- parameter 9904 is set to 3 (SCALAR: FREQ), and parameter 2101 is set to 3 (SCALAR FLYSTART) or 5 (FLY + BOOST).  
If your selection is 0 (OFF/IDMAGN), move to the next step.  
Value 1 (ON) should be selected if:
  - the operation point is near zero speed, and/or
  - operation at torque range above the motor nominal torque over a wide speed range and without any measured speed feedback is required. If you decide to do the ID Run (value 1 (ON)).

### IDENTIFICATION MAGNETIZATION WITH RUN SELECTION 0 (OFF)

Press  key to switch to local control (LOC shown on the left).

Press  to start the drive. The motor model is now calculated by magnetizing the motor for 10 to 15 s at zero speed.









# T-Line 90 & 120 Extract Units

Installation, Operation and Maintenance Manual

## Start-Up12

Continued

### DIRECTION OF MOTOR ROTATION

- Check the direction of the motor rotation.
- If the drive is in remote control (REM shown on the left), switch to local control by pressing .
- To go to the Main menu, press  if the bottom line shows OUTPUT; otherwise press  repeatedly until you see MENU at the bottom.
- Press keys  /  until you see .rEF. and press .
- Increase the frequency reference from zero to a small value with key .
- Press  to start the motor.
- Check that the actual direction of the motor is the same as indicated on the display (FWD means forward and REV reverse).
- Press  to stop the motor.
- To change the direction of the motor rotation:
- Disconnect input power from the drive, and wait 5 minutes for the intermediate circuit capacitors to discharge. Measure the voltage between each input terminal (U1, V1 and W1) and earth with a multimeter to ensure that the drive is discharged.
- Exchange the position of two motor cable phase conductors at the drive output terminals or at the motor connection box.
- Verify your work by applying input power and repeating the check as described above.

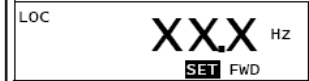

forward direction

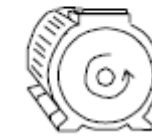

reverse direction

### SPEED LIMITS AND ACCELERATION/DECLARATION TIMES

- Set the minimum speed (parameter 2001).
- Set the maximum speed (parameter 2002).
- Set the acceleration time 1 (parameter 2202).
- Note:** Check also acceleration time 2 (parameter 2205) if two acceleration times will be used in the application.
- Set the deceleration time 1 (parameter 2203).  
**Note:** Set also deceleration time 2 (parameter 2206) if two deceleration times will be used in the application.

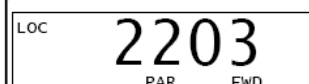

## T-Line 90 & 120 Extract Units

Installation, Operation and Maintenance Manual

### Start-Up 12

Continued

#### SAVING A USER MACRO AND FINAL CHECK

<p><input type="checkbox"/> The start-up is now completed. However, it might be useful at this stage to set the parameters required by your application and save the settings as a user macro.</p> <p><input type="checkbox"/> Check that the drive state is OK.          Basic Control Panel: Check that there are no faults or alarms shown on the display. If you want to check the LEDs on the front of the drive, switch first to remote control (otherwise a fault is generated) before removing the panel and verifying that the red LED is not lit and the green LED is lit but not blinking.          Assistant Control Panel: Check that there are no faults or alarms shown on the display and that the panel LED is green and does not blink.</p> <p>The drive is now ready for use.</p>	<table border="1" style="margin: auto;"> <tr> <td style="padding: 5px;">           LOC  <span style="font-size: 2em; font-weight: bold;">9902</span>            PAR      FWD         </td> </tr> </table>	LOC <span style="font-size: 2em; font-weight: bold;">9902</span> PAR      FWD
LOC <span style="font-size: 2em; font-weight: bold;">9902</span> PAR      FWD		

### Preprogrammed 13 Faults

CODE	FAULT	CAUSE	WHAT TO DO
0001	OVERCURRENT (2310) 0305 bit 0	Output current has exceeded trip level.	Check motor load. Check alteration time (2202 and 2205). Check motor and motor cable (including phasing). Check ambient conditions. Load capacity decreases if installation site ambient temperature exceeds 40°C. See section <i>Derating</i> on page 291.
0002	DC OVERVOLT (3210) 0305 bit 1	Excessive intermediate circuit DC voltage. DC overvoltage trip limit is 420 V for 200 V drives and 840 V for V drives.	Check that overvoltage controller is on (parameter 2005 OVERVOLT CTRL). Check input power line for static or transient overvoltage. Check deceleration time (2203,2206).
0003	DEV OVERTEMP (4210) 0305 bit 2	Drive IGBT temperature is excessive. Fault trip limit is 135°C	Check ambient conditions. See also <i>Derating</i> on page 291. Check airflow and fan operation. Check motor power against unit power.
0004	SHORT CIRC	Short circuit motor Cable(s) or motor.	Check motor and motor cable.
0006	DC UNDERVOLT (3220) 0305 bit 5	Intermediate circuit DC voltage is not sufficient due to missing input power line phase, blown fuse, rectifier bridge internal fault or too low input power.	Check that undervoltage controller is on (parameter 2006 UNDERVOLT CTRL). Check Input power supply and fuses.

## T-Line 90 & 120 Extract Units

Installation, Operation and Maintenance Manual

### Preprogrammed 13

#### Faults

Continued



CODE	FAULT	CAUSE	WHAT TO DO
0034	MOTOR PHASE (FF56) 0306 bit 14	Motor circuit fault due to missing motor phase or motor thermistor relay (used in motor temperature measurement) fault.	Check motor and motor cable. Check motor thermistor relay (if used).
0017	UNDERLOAD (FF6A) 0306 bit 0 (programmable faultfunction 3013.. ..3015)	Motor load is too low due to e.g. release mechanism in driven equipment.	Check for problem in driven equipment. Check fault function parameters. Check motor power against unit power.
0022	SUPPLY PHASE (3130) 0306 bit 5 (programmable fault function 3016)	Intermediate circuit DC voltage is oscillating due to missing input power line phase or blown fuse. Trip occurs when DC voltage ripple exceeds 14% of nominal DC voltage.	Check input power line fuses. Check for input power supply imbalance. Check fault function parameters.

### Fault Tracing 14

#### Alarm and fault indications

Fault is indicated with a red LED. An alarm or fault message on the panel display indicates abnormal drive status. Using the information given in this chapter most alarm and fault causes can be identified and corrected. If not, contact an ABB representative. The four digit code number in parenthesis after the alarm/fault is for the fieldbus communication.

#### How to reset

The drive can be reset either by pressing the keypad key  (Basic Control Panel) or (Assistant Control Panel), through digital input or fieldbus, or  by switching the supply voltage off for a while. The source for the fault reset signal is selected by parameter 1604 FAULT RESET SEL. When the fault has been removed, the motor can be restarted.

#### Fault history

When a fault is detected, it is stored in the Fault History. The latest faults are stored together with the time stamp. Parameters 0401 LAST FAULT, 0412 PREVIOUS FAULT 1 and 0413 PREVIOUS FAULT 2 store the most recent faults. Parameters 0404..0409 show drive operation data at the time the latest fault occurred. The Assistant Control Panel provides additional information about the fault history.

# T-Line 90 & 120 Extract Units

Installation, Operation and Maintenance Manual

## Maintenance 15

**Important**  Before attempting to carry out any work on our units, all accompanying documentation including warning labels on the unit must be referenced. Should it be necessary to remove any component ensure that these are secured into position once reinstalled. It is critical that after any maintenance work has been conducted that all components removed/replaced be refitted correctly by a competent engineer

**Warning**  Before attempting to carry out any maintenance work, investigative or repair work on our units, the unit **MUST BE COMPLETELY ISOLATED** from its electrical supply. Ensure a minimum of two minutes after electrical disconnection before removing access panels.

**Caution**  Ensure impellor has been allowed to completely stop before attempting to carry out any work on this unit.

**Caution**  Ensure the unit has been allowed to completely cool before attempting any work to the unit.

**Caution**  When accessing the unit always use the handles to ensure the access panels are handled/opened in a controlled manner so as to avoid damage to the unit or injury to personnel. This is particularly important with bottom access units. Once maintenance has been carried out ensure the motor assembly is secured correctly before restarting the unit, refer to page 22

In general, this series of units require little maintenance. Regular inspection for damage and cleaning. In the unlikely event of component failure, spares are available from stock at VES.

**Important**  The impellor should rotate freely and this position is factory set. In the unlikely event of movement during transit or operation realign the impellor with the inlet eye.

Remove the access panels and loosen the bolts holding the inlet eye in place. Align the inlet eye and impellor ensuring the inlet eye is central to the impellor and make sure gap A is constant. Hand tighten the bolts and rotate the impellor to ensure the it runs smoothly, secure into position by tightening the retaining bolts.

Impellor/Inlet Eye Alignment

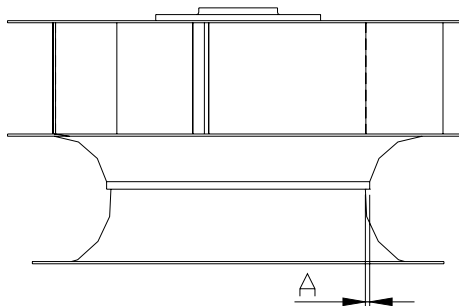

# T-Line 90 & 120 Extract Units

Installation, Operation and Maintenance Manual

## Maintenance 15

Continued

Caution  Ensure that the clearance gap "A" between fan and inlet eye is constant. Misalignment may cause undue wear on the impellor and inlet eye.

Always make sure the fan is rotating in the correct direction (anti-clockwise when viewed from the motor). Direction of airflow is indicated on the unit.

Impellor rotation

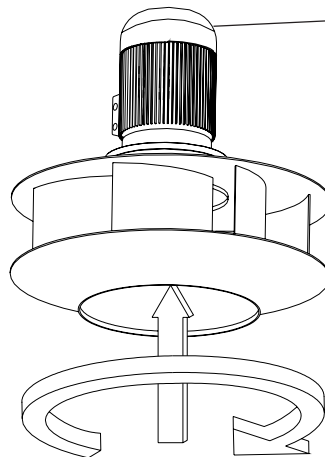

**Note:** Motor rotation can be seen on the motor cooling fan on the end of the motor. WP units may the require temporary removal of motor cover.

In order to remove the motor plate for maintenance remove the fixings and secure lifting cable to lugs, also ensure the isolator has been disconnected refer to page 5. Ensure fan assembly is tightned before lifting the motor plate off.

Lifting Fan Assembly

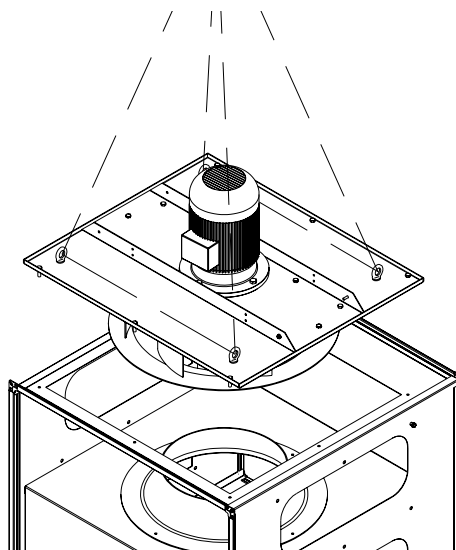

# T-Line 90 & 120 Extract Units

Installation, Operation and Maintenance Manual

## Maintenance 15

Continued

**Caution** If dismantlement is required due to a blockage ensure motor and impellor are reassembled and installed correctly as in the following diagram. For isolator bracket removal refer to page 5.

### Fan Assembly

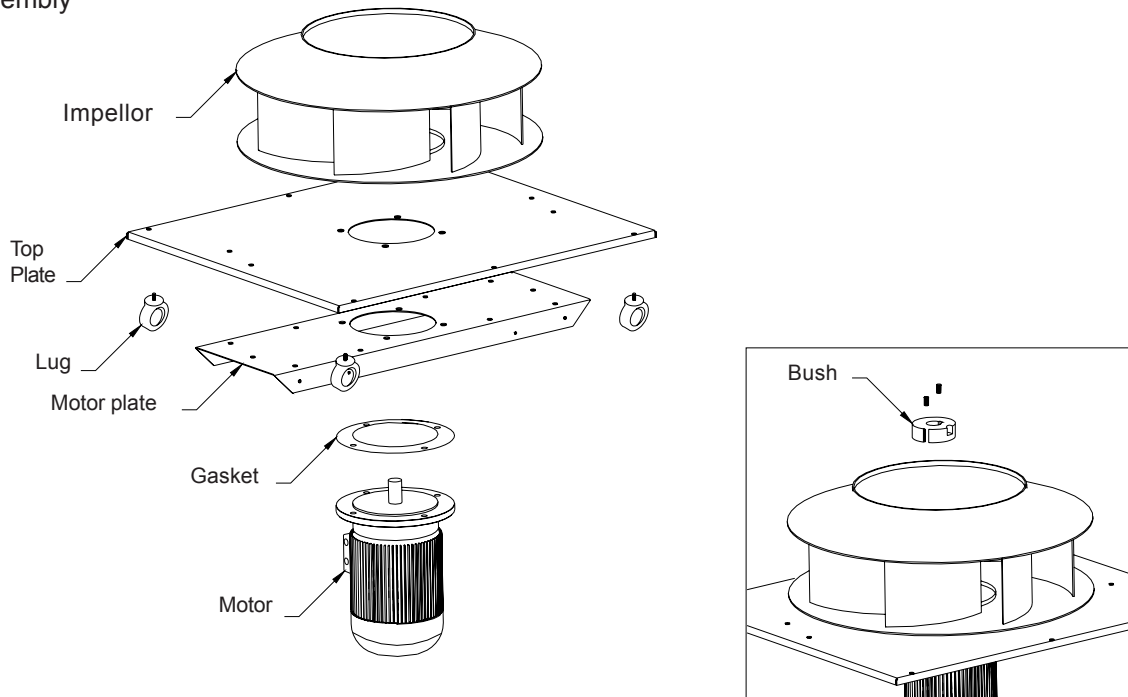

**Important** When re-assembling the fan and motor ensure the bush is secured tightly to the motor shaft with the impellor correctly aligned. Ensure the impellor rotates freely leaving a level gap of B (as shown below) between the impellor and the top plate.

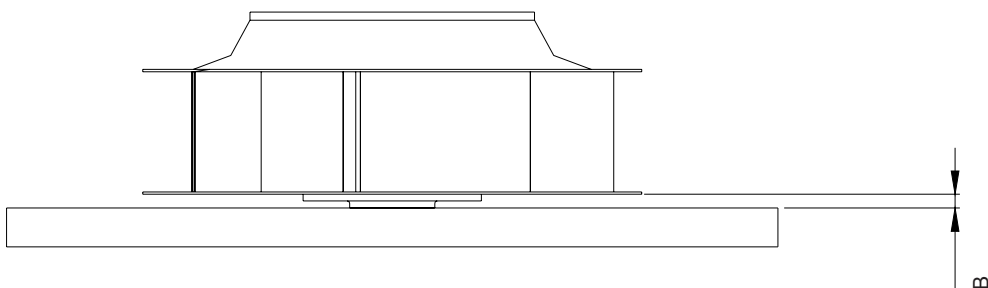

Size	Distance B
250	20mm
350	20mm
400	25mm
450	25mm
500	20mm
560	32mm
630	32mm
710	28mm
800	32mm

## T-Line 90 & 120 Extract Units

Installation, Operation and Maintenance Manual

### Maintenance 15

Continued

#### Recommended Checks

In order to keep the unit in good order the following maintenance routine is recommended

#### Six Monthly Checks

The fan impellor should be cleaned every 6 months. Failure to clean the fan on a regular basis could result in loss of fan performance, or cause it to fall out of balance. If a fan is stationary for long periods in a humid atmosphere, it should be switched ON for minimum of two hours every month to remove any moisture that may have condensed within the motor.

#### Twelve Monthly Checks

T-Line units are supplied in both unpainted and powder coat painted galvanised sheet steel cases. Check all painted items to ensure that they have not deteriorated, particularly where adverse environmental conditions prevail. Re-paint as necessary. Matching paint can be supplied upon request.

#### Spares & repairs

When enquiring about or ordering spares contact VES Spares Department, quoting the sales order (SO) number and unit type found on the unit nameplate.

Tel: 08448 15 60 60 - Fax: 02380 26 12 04

#### WEEE Directive



At the end of their useful life the packaging and product should be disposed of via a suitable recycling centre. Do not dispose of with normal household waste. Do not burn



**PLEASE ENSURE THAT THIS DOCUMENT IS PASSED  
ON TO THE END USER**

*We reserve the right to alter the specification without notice © VES Andover Ltd. 2010 No part publication may be photocopied or otherwise reproduced without the prior permission in writing of VES Andover.*

## T-Line 90 & 120 Extract Units

Installation, Operation and Maintenance Manual

### Declaration of 16 Conformity



### Declaration of Conformity

Date: 12th April 2010  
Product: T-Line  
Type: Extract Units  
Manufacturer: VES Limited

The product above is produced in accordance with EC Council Directives:

2006/42/EC (Machinery Directive)  
2004/108/EE (Electromagnetic Compatibility Directive)

The European Harmonised Standards applied are:

BS EN ISO 12100, EN 294, EN61000, EN 60204-1, EN60950

The National Standards applied in particular are :

BS 848 Part 1

Basis of Self attestation:

Quality Assurance to ISO 9001-2000, BSI Reg. Firm Cert. No. Q5375

Signature of Manufacturer:



Position of Signatory:

## T-Line 90 & 120 Extract Units

Installation, Operation and Maintenance Manual

### Warranty 17

#### Extended Warranties

All VES Andover Products come with a one year guarantee from date of dispatch, which covers parts and labour.

You can now extend this with the following options:

#### Option 1. FREE extended Warranty

We can offer you a maintenance agreement that keeps this equipment in tip-top condition. If you take out this agreement, we will extend the warranty **free of charge for up to 5 years**, providing the regular maintenance agreement remains in place.

#### Option 2. 12-24 Month Extended Warranty

12-24 months from the date of dispatch. This can be covered at a cost of just 3% of order value. (minimum charge £50.00).

#### Option 3. 12-36 Month Extended Warranty

12-36 months from date of dispatch. For this cover, the charge is 6% of order value (Minimum charge £80)

Please State which option you require when you place your order. A transferable certificate will then be issued to you.

Please note, this offer excludes condensing units. We would be happy to quote you for these separately.

**VES Spares offer a six monthly free reminder service. This can help ensure your equipment is kept in optimum condition.**  
**If you would like to subscribe to this service, please call Spares on 02380 461 153.**  
**Once subscribed you will be eligible to a 5% regular user discount off of replacement filter prices and a fixed £20.00 carriage charge for all UK Main Land deliveries.**  
**VES can also offer Spares for existing units for requirements that are over 40 years old.**

To arrange any of these options.

**Phone: 08448 15 60 60**

**or Email: spares@ves.co.uk**

Stating the sales order and reference number from the unit.