

VES Controls

CONTROL SYSTEMS

For flexibility and performance

Stand alone or full building integration BMS

Intelligent control for application and energy optimising

BlueSense energy saving packages with demand ventilation control



VES CONTROLS

*system design, manufacture,
installation and maintenance*

Why choose VES

VES has been supplying products for the HVAC industry for over 40 years, and have the in-depth knowledge and resources to provide solutions to all ventilation related requirements. We are a substantial British manufacturing company with over 250 employees, several factories plus a regional base in the north of England, and sales engineers located throughout the UK.

Complete range of products

The product range encompasses all types of ventilation products, including those required for commercial, industrial, public and domestic buildings. The emphasis is on low energy products and sophisticated controls to meet the requirements of the Building Regulations.

The range extends from a small bathroom extract fan up to a mighty central station air handling unit. There are specialist heat recovery units, high temperature fans for kitchen hood extract; duct, wall, ceiling and roof units; low noise products, silencers and fitted controls.

High quality, flexible solutions

VES operates a quality assurance system to ISO 9001, monitored by the BSI. The air movement products are tested in-house to BS 848: Part 1, and submitted for external testing and approval when necessary.

VES specialise in bespoke designs for ventilation units, and whatever the issue, be it space, noise, temperature etc, can provide a design solution to meet the requirements of the project.

Superior customer service

From the moment we receive your enquiry to delivery and beyond, we have the people in place to give excellent customer service. The VES after sales service covers the whole of the UK and is among the best in the industry.

Experience and expertise

VES employs a range of experts in disciplines including air movement, noise control, air conditioning, controls, electrics and product refurbishment, and we have key staff who have worked at VES for many years.

Manufactured in the UK

VES has over 12000m² of manufacturing and stores space, and has state of the art sheet metalworking equipment, plus a large powder coating plant. VES also has a substantial controls department, and makes components such as dampers and electric heaters in-house. This not only provides employment for local people, but also many suppliers around the UK.



Better air for the built environment

Features

Philosophy

Supply or Return Air Control,
Humidity, Enthalpy,
Constant Pressure or Volume.
Energy Saving and Monitoring.

BMS

Stand Alone, Read Only
or Full Integration.
Modbus®, BACnet®, TREND®.

HMI

Human Machine Interface

Basic,
Monochrome TFT Touch Screen,
Colour TFT Touch Screen,
Within Control Panel,
Panel Facia Mounted,
Remote.

Sensors



Temperature,
Air Quality,
Humidity.
Pressure.
Velocity.

Speed Control

Inverter, Transformer, Thyristor.
Independent, Manual,
Synchronised with BMS,
Responding to Sensor.

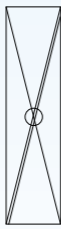

Heat Recovery

Plate Heat Exchanger Face and
Bypass Damper,
Constant / Variable Thermal
Heat Wheel,
Run-Around Coil,
Mixing Box,
Enthalpy.



Supply / Extract Fan

Single or Three Phase
Speed Control,
for Commissioning,
Demand Ventilation,
Constant Pressure.
Air Flow Proving.



Heater

Main Heater
Pre-heater, Frost Heater:
Electric Thyristor or Stepped,
LPHW, Steam,
Gas In-direct
and Direct Heatpump.
Boiler and Gas Interlock.

Overview

Application Schematic

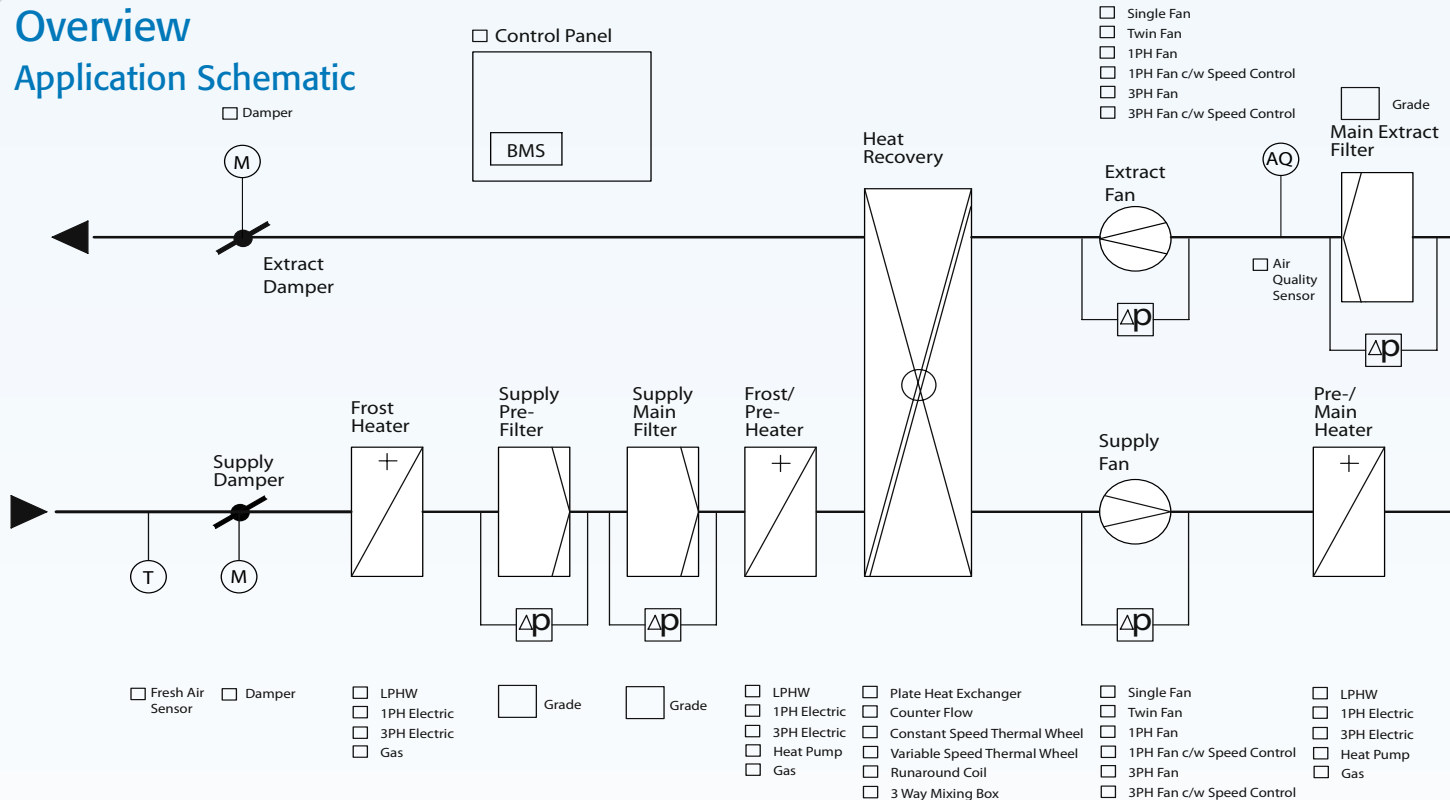

Specification

		User Selection	CPE1 - Page 6	CPE4 & CPE9 - Page 6	CPW - Page 6	CPA RW - Page 7	CPA RE - Page 7	CPA BW - Page 7	CPA BE - Page 7	CPB Electric - Page 8	CPB Water - Page 8	CPC Electric Remote Touch Screen - Page 9	CPC - Water Remote Touch Screen - Page 9
Supply fan - control, monitoring and commissioning	230Vac 50Hz or 400Vac 50Hz		✓	✓	✓	✓	✓	✓	✓	✓	✓	✓	✓
Extract fan - control, monitoring and commissioning	230Vac 50Hz or 400Vac 50Hz			✓	✓	✓	✓	✓	✓	✓	✓	✓	✓
Electric stepped heating	230Vac 50Hz or 400Vac 50Hz		✓	✓		✓	✓					✓	✓
Electric modulating Thyristor heating	230Vac 50Hz or 400Vac 50Hz						✓		✓			✓	✓
Heating and cooling recovery	Modulating								✓	✓	✓	✓	✓
	On/Off								✓	✓	✓	✓	✓
LPHW modulating heating and frost protection					✓	✓		✓		✓	✓	✓	✓
Cooling control	Modulating					✓	✓	✓	✓	✓	✓	✓	✓
	On/Off								✓	✓	✓	✓	✓
Volt free remote start/stop			✓	✓	✓	✓	✓	✓	✓	✓	✓	✓	✓
7 day time clock			✓	✓	✓	✓			✓	✓	✓	✓	✓
Panel display unit									✓	✓			
External source (eg.BMS)								✓	✓	✓	✓		
Supply and extract damper control (24Vdc or 230Vac)									✓	✓		✓	✓
Volt free common run and trip indication						✓	✓	✓	✓	✓	✓	✓	✓
Common filter dirty indicator												✓	✓
365 day time clock												✓	✓
Remote touch screen - control and optimisation												✓	✓
Remote room controller						✓	✓						
Intelligent start and set back												✓	✓
Demand ventilation												✓	✓
Supply room/extract or supply air with limitation control												✓	✓
Sensors	Supply air									✓	✓	✓	✓
	Optional duct sensor					✓	✓						
	Duct sensor		✓	✓	✓								
	Optional room sensor		✓	✓	✓								
	Extract air									✓	✓	✓	✓
	Built in room air sensor					✓	✓						
	Fresh air									✓	✓	✓	✓
Communication	Modbus® option											✓	✓
	BACnet® option											✓	✓
Internal or external locations						✓	✓	✓	✓	✓	✓	✓	✓
BlueSense - Energy Saving Package													
	Energy efficient speed control					✓	✓	✓	✓	✓	✓	✓	✓
	Air quality sensor (CO ₂ & VOC)					✓	✓	✓	✓	✓	✓	✓	✓
	Post installation optimising					✓	✓	✓	✓	✓	✓	✓	✓

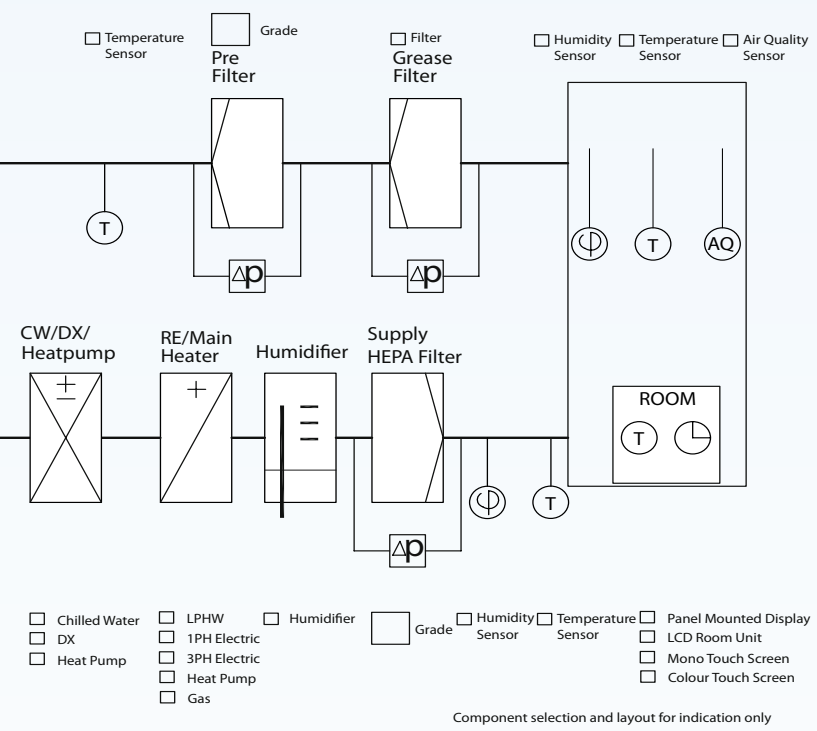

Contents



Introduction
Page 4-5

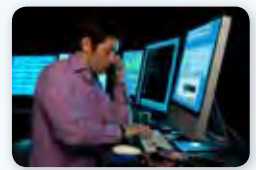

BMS Integration
Page 13



Products
Pages 6-9



User Interfacing
Page 14



Specials
Page 12



Sensors & Speed Controls
Page 15



See pages 10-11 for further information on BlueSense.

Use this chart to forward your full HVAC enquiry direct to VES. Please enter your requirements in the appropriate boxes, complete the contact details and return to sales@ves.co.uk. Alternatively visit www.ves.co.uk/products/controlsenquiry or call +44(0)8448 15 60 60 to order now.

Name	<input type="text"/>	Company Name	<input type="text"/>
Enquiry Reference	<input type="text"/>	Email Address	<input type="text"/>
Phone Number	<input type="text"/>	Mobile Number	<input type="text"/>

Control Philosophy: tick below as required

Temperature	Supply air	<input type="checkbox"/>	Return air	<input type="checkbox"/>	Room	<input type="checkbox"/>	Close control	<input type="checkbox"/>
Variable speed	For commissioning only	<input type="checkbox"/>	AQ/CO ₂ demand	<input type="checkbox"/>	Constant pressure	<input type="checkbox"/>	Nominal pressure Pa	<input type="text"/>
Dehumidification		<input type="checkbox"/>						
Enthalpy		<input type="checkbox"/>						
Energy monitoring		<input type="checkbox"/>						
Kitchen gas interlock		<input type="checkbox"/>						
Communication protocol	Stand alone	<input type="checkbox"/>	BACnet® IP	<input type="checkbox"/>	Modbus®	<input type="checkbox"/>	Other	<input type="checkbox"/>
Location	Loose	<input type="checkbox"/>	Fitted & pre-wired to AHU	<input type="checkbox"/>				

Additional notes please use this space to add further information

AHU Selection: control will be added for each component

Location	Internal	<input type="checkbox"/>	External	<input type="checkbox"/>				
Supply duty	<input type="text"/>	m ³ /s @	<input type="text"/>	Pa				
Extract duty	<input type="text"/>	m ³ /s @	<input type="text"/>	Pa				
Layout	Flat	<input type="checkbox"/>	Stacked	<input type="checkbox"/>				
Pre heating	LPHW	<input type="checkbox"/>	Electric	<input type="checkbox"/>	Duty	<input type="text"/>		
Main heating	LPHW	<input type="checkbox"/>	Electric	<input type="checkbox"/>	Duty	<input type="text"/>		
Cooling	DX	<input type="checkbox"/>	CW	<input type="checkbox"/>				
Conditions	<input type="text"/>	db/	<input type="text"/>	wb to	<input type="text"/>	db/	<input type="text"/>	wb
Heat pump	<input type="text"/>							
Heat recovery	Plate exchanger c/w face & bypass	<input type="checkbox"/>	Heat wheel	<input type="checkbox"/>	Other	<input type="checkbox"/>		
Pre filter grade	<input type="text"/>							
Main filter grade	<input type="text"/>							

Additional notes please use this space to add further information

Introduction

VES manufactures control panels for HVAC applications, enabling the designer to specify exactly what functions are required. The panels are built by VES to the highest industry standards, economic in price, and if not fitted to an AHU are easy to install and commission.

VES offers a unique blend of product features and services tailored to a very large variety of challenging projects. Our expert team can custom design, manufacture and install control solutions for a wide variety of applications, including highly specialised buildings such as the Wallop Defence Systems Ltd project detailed on page 5.

Our BlueSense range of products, with integrated controls packages and demand ventilation, provide excellent energy and performance efficiencies. This provides significant cost savings over the lifetime of the unit.

Our Control Products



VES manufactures a wide range of control panels for HVAC systems and related industries, built to the highest standards with applications to suit all budgets.

Features

- ▶ Wide range of options from entry level to powerful digital controls.
- ▶ Flexible standard designs.
- ▶ Bespoke to order.
- ▶ Loose or factory fitted, pre-wired and factory commissioned by VES.
- ▶ Value and performance.

Products

- ▶ Control Panels.
- ▶ Sensors.
- ▶ Speed Controllers.
- ▶ Customer Interfaces.
- ▶ Specials.

Standard and Bespoke Solutions



VES provides complete control solutions for ventilation equipment, these flexible packages are available as compact standards or specialised customised systems.

Features

- ▶ Expertise in temperature, heating and cooling recovery, humidity and pressure solutions from individual room to overall building control.
- ▶ Demand ventilation to maximise energy savings incorporating CO₂, occupancy and control optimisation.
- ▶ Standalone systems or full integration into Building Management Systems using a variety of communication protocols.

Demand Ventilation Solutions



BlueSense philosophy combines intelligent control technologies with energy saving products, services and engineering expertise. BlueSense helps meet energy reduction commitments by optimising the equipment performance, improving energy efficiency, saving money and increasing equipment life expectancy.

Features

- ▶ Inbuilt intelligent controls technology.
- ▶ Optimises performance and efficiency.
- ▶ Demand ventilation control improves air quality, reducing energy consumption and lowering operating costs.
- ▶ Combined CO₂ and VOC (Volatile Organic Compounds) sensing technology with energy efficient speed control.
- ▶ Extending equipment life expectancy and reducing maintenance.
- ▶ Short term payback on capital expenditure.

Use VES BlueSense to achieve project requirements whilst reinforcing your commitments to best practice and sustainability.

VES Designs and Manufactures Controls



VES designs and manufactures control systems at our factory in Chandlers Ford, Hampshire, producing panels and customised solutions for the UK and European HVAC and associated industries.

Features

- Pre-sales support ensures smooth project installation.
- All control panels designed and manufactured in house.
- Off the shelf or tailor made solutions to meet specific requirements.
- Extensive technical support with both remote and on site assistance.
- Intuitive interfaces for ease of operation.

Understanding BMS (Building Management System)

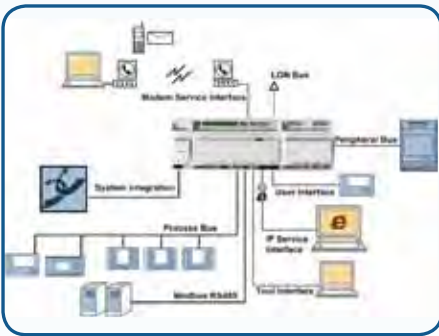

The understanding and application of BMS can be widely misunderstood, either too simplified or over complicated, with multiple terms being applied ie BMS, BMES, BAC and BAS etc. The terminology *building automation and control* refers to the central management, monitoring, and optimisation of building technology using a computer-based building automation and control system. Building automation and control systems are installed in a multitude of applications including larger office buildings, shopping centres, hospitals, etc., where complex electrical and mechanical plants interact in such a way that there is ample opportunity to optimise both building performance and energy consumption.

Features

- VES offers and supports many styles of control package, from stand alone to fully integrated.
- Open communication protocols, such as Modbus® or BACnet®, are preferred for integrated systems with all design and support being provided by in house engineers.
- Other platform systems e.g TREND® may also be provided or we can incorporate free issued platforms.
- Our aim is to provide flexible, straightforward operation and satisfy individual customer needs, protecting investments in the long term.

VES Comprehensive Support



VES understands that our customers may require assistance with design, installation or commissioning. Our in house staff are available as a resource to assist with all stages of the project.

Features

- Pre-sales support and design at the customers or consultants office.
- Site and installation surveys.
- On-site assembly, wiring or supervision.
- Post installation checks prior to initial operation.
- Controls site optimisation to ensure system is commissioned for maximum energy saving.
- Energy audits and calculations.

Case Study: Wallop Defence Systems Ltd



VES provided expert design assistance to Wallop. Bespoke advanced controls loops were designed to control temperature, humidity and dehumidification with the prime focus on equipment safety measures and warning systems.

CPE & CPW Range

Simple Wall Mounted Panels



The CPE & CPW range offer standard designs for wall mounting, that are simple to install and operate. These are available on very short lead times.

CPE Range

Features

- ▶ Single phase supply and extract fan starter.
- ▶ Stepped single phase electric heating.
- ▶ 7 day time clock.
- ▶ Panel mounted temperature adjustment.
- ▶ Duct sensor or optional room sensor.

Electric Heating Options (Max)

- ▶ CPE1 - 3kW 1x1 (1PH supply).
- ▶ CPE4 - 12kW 4x1 (1PH or 3PH supply).
- ▶ CPE9 - 27kW 9x1 (1PH or 3PH supply).

CPW Range

Features

- ▶ Single phase supply and extract fan starter.
- ▶ LPHW heating with frost protection.
- ▶ 7 day time clock.
- ▶ Panel mounted temperature adjustment.
- ▶ Duct sensor or optional room sensor.

Specification CPE - Electric Heating / CPW - Hot Water Heating

	Model	CPE1	CPE4 & CPE9	CPW
Supply fan	230Vac 50Hz	✓	✓	✓
Extract fan	230Vac 50Hz		✓	✓
Electric stepped heating	230Vac 50Hz	✓	✓	
LPHW modulating heating and frost protection				✓
Volt free remote start/stop		✓	✓	✓
7 day time clock			✓	✓
Temperature sensor	Duct sensor	✓	✓	✓
	Optional room sensor	✓	✓	✓
Internal locations only		✓	✓	✓

See page 12 for Specials

VES Controls provide freely programmable controllers that can be tailored to any specific requirement ranging from dedicated control loops to integration into Building Management Systems and energy optimisation.

For further information on our flexibility and expertise go to the Specials section on page 12.

CPE Example

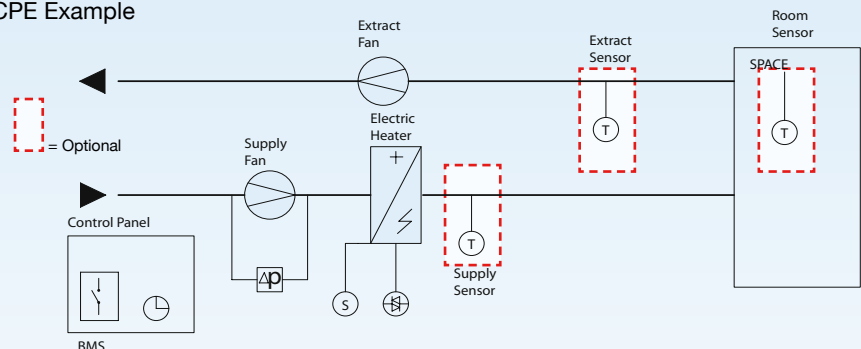

CPA Range

Remote and Room Control for AHUs

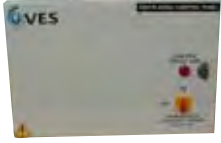

The CPA range is specifically designed for air handling units requiring remote or room unit control, with applications suitable for individual supply and/or extract systems.

The control system can be supplied in a stand alone enclosure or fully integrated into an air handling unit. For individual room control the panel is supplied with a LCD room unit with a in-built temperature sensor. For remote unit control through a BMS system or other external source the panel is supplied with terminals for easy customer connections.

Features

- ▶ Single or three phase electric Thyristor or LPHW modulating heating control.
- ▶ Optional versatile LCD room unit with in-built temperature sensor and timers.
- ▶ Adjustable control parameters to suit individual applications.
- ▶ Extensive built-in safety features.
- ▶ Value and performance.
- ▶ Compatible with speed controller and air quality sensor for energy efficient demand ventilation solution (BlueSense).

Specification CPA - Electric Heating/Hot Water Heating

	Model	Room Unit		BMS Unit	
		Electric	Water	Electric	Water
Supply fan	230Vac 50Hz or 400Vac 50Hz	✓	✓	✓	✓
Extract fan	230Vac 50Hz or 400Vac 50Hz	✓	✓	✓	✓
Electric modulating Thyristor heating	230Vac 50Hz or 400Vac 50Hz	✓		✓	
LPHW modulating heating and frost protection			✓		✓
Chilled water modulating cooling		✓	✓	✓	✓
Volt free remote start/stop		✓	✓	✓	✓
24Vdc Fire alarm shutdown		✓	✓	✓	✓
Supply and extract volt free signals		✓	✓	✓	✓
Volt free common run and trip indication		✓	✓	✓	✓
Remote control unit with in-built room air temperature sensor		✓	✓		
7 day time clock		✓	✓		
External source control (BMS) 0-10Vdc demand input and volt free start/stop				✓	✓
Optional duct temperature sensor		✓	✓		
Internal or external locations		✓	✓	✓	✓
BlueSense - Energy Saving Package					
Energy efficient speed control		✓	✓	✓	✓
Air quality sensor (CO ₂ & VOC)		✓	✓	✓	✓
Post installation optimising		✓	✓	✓	✓



Energy monitoring is an effective way of highlighting areas for potential savings whilst providing a key indicator to ongoing energy consumption.

See page 10-11

CPA Example

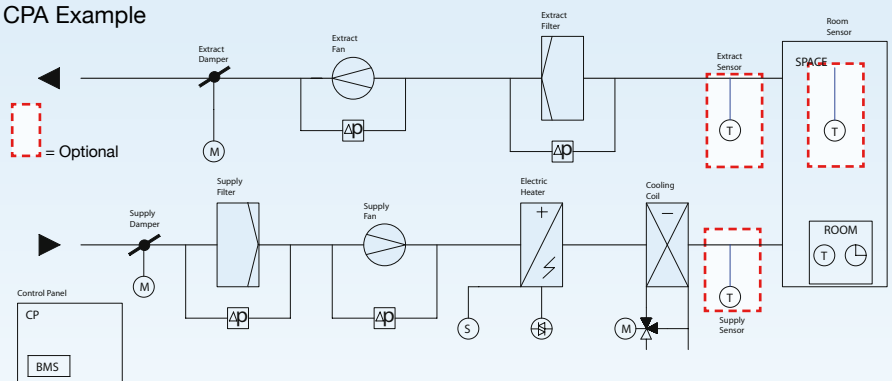

CPB Range

Entry Level Heat Recovery Panels



The CPB range is specifically designed for use in entry level heat recovery applications. The control system can be supplied in a standalone enclosure or fully integrated in a supply or heat recovery air handling unit. For remote unit control through BMS or other external source the panel is supplied with terminals for easy customer connections.

Features

- ▶ Single or three phase electric Thyristor or LPHW modulating heating control.
- ▶ Versatile panel mounted LCD display with adjustable control parameters to suit individual applications.
- ▶ Optional remote user interface available.
- ▶ Extensive built in safety features; isolation, airflow monitoring and thermal cut-out.
- ▶ Heat recovery control for use with plate heat exchanger, 3 way mixing box or heat wheels.
- ▶ Compatible with speed controller and air quality sensor for an energy efficient demand ventilation solution.

Specification CPB - Electric Heating/Hot Water Heating

	Model	CPB Electric	CPB Water
Supply fan	230Vac 50Hz or 400Vac 50Hz	✓	✓
Extract fan	230Vac 50Hz or 400Vac 50Hz	✓	✓
Electric modulating Thyristor heating	230Vac 50Hz or 400Vac 50Hz	✓	
Heating and cooling recovery	Modulating	✓	✓
	On/Off	✓	✓
LPHW modulating heating and frost protection			✓
Chilled water modulating cooling		✓	✓
Volt free remote start/stop		✓	✓
24Vdc fire alarm shutdown		✓	✓
Supply and extract damper control (24Vdc or 230Vac)		✓	✓
Volt free common run and trip indication		✓	✓
Panel display unit		✓	✓
7 day time clock		✓	✓
External source control (eg BMS)		✓	✓
Temperature sensors	Supply air	✓	✓
	Extract air	✓	✓
	Fresh air	✓	✓
Internal or external locations		✓	✓
BlueSense - Energy Saving Package			
Energy efficient speed control		✓	✓
Air quality sensor (CO ₂ & VOC)		✓	✓
Post installation optimising		✓	✓

See page 12 for Specials

VES Controls provide freely programmable controllers that can be tailored to any specific requirement ranging from dedicated control loops to integration into Building Management Systems and energy optimisation.

CPB Example

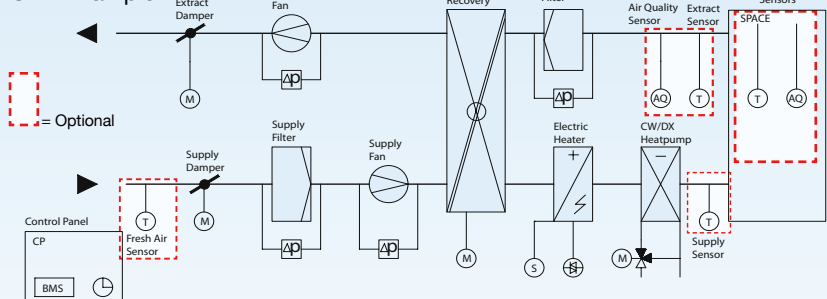

CPC Range

Powerful and Versatile Controls for AHUs



The CPC range is specifically designed for higher specification air handling units and has a powerful pre-programmed digital controller that utilises intelligent software for flexibility and optimising performance. The CPC range can be coupled with a variety of different operator interfaces including simple room units, monochrome and colour touch screens or communications to Building Management Systems.

The CPC range provides full HVAC functionality including control loops, time schedules, alarm management etc, with application optimising via parameter settings within the remote unit.

Features

- ▶ Simple BMS interface or communication through Modbus® and BACnet®.
- ▶ Intelligent start time offset adjusted in response to outside temperature.
- ▶ Intuitive user access for operation and commissioning.
- ▶ Compatible with speed controller and air quality sensor for energy efficient demand ventilation solution.
- ▶ Energy monitoring and optimisation providing real-time energy consumption, heat recovery efficiency and automatic parameter adjustment between Comfort and Economy; setpoint, deadband, air quality, fan speed, optimal start/stop etc.

Specification CPC - Electric Heating/Hot Water Heating

	Model	CPC - Electric Remote Touch Screen	CPC - Water Remote Touch Screen
Supply fan - control, monitoring and auto-commissioning	230Vac 50Hz or 400Vac 50Hz	✓	✓
Extract fan - control, monitoring and auto-commissioning	230Vac 50Hz or 400Vac 50Hz	✓	✓
Electric modulating Thyristor heating	230Vac 50Hz or 400Vac 50Hz	✓	
Heating and cooling recovery	Modulating	✓	✓
	On/Off	✓	✓
LPHW modulating heating and frost protection			✓
Cooling control	Modulating	✓	✓
	On/Off	✓	✓
Inverter driven heat pump and pre-heater option		✓	✓
Volt free remote start/stop		✓	✓
24Vdc fire alarm shutdown		✓	✓
Supply and extract damper control (24Vdc or 230Vac)		✓	✓
Volt free common run and trip indication		✓	✓
Intelligent start/stop and setback		✓	✓
Energy monitoring and optimisation		✓	✓
365 day time clock		✓	✓
User interface - control and optimisation	Panel display unit	✓	✓
	Optional remote touch screen	✓	✓
Remote touch screen - control and optimisation		✓	✓
Common filter dirty indicator		✓	✓
Demand ventilation		✓	✓
Supply, room, extract or supply air with limitation control		✓	✓
Temperature sensors	Supply air	✓	✓
	Extract air	✓	✓
	Fresh air	✓	✓
Communication	Modbus® option	✓	✓
	BACnet® option	✓	✓
	Web browser option	✓	✓
Internal or external locations		✓	✓
BlueSense - Energy Saving Package			
Energy efficient speed control		✓	✓
Air quality sensor (CO ₂ & VOC)		✓	✓
Post installation optimising		✓	✓



Energy monitoring is an effective way of highlighting areas for potential savings whilst providing a key indicator to ongoing energy consumption.

See page 10-11

CPC Example

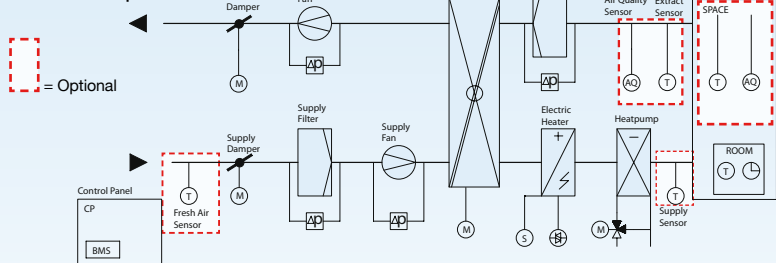

Controls packages for performance and efficiency



Save energy and costs with BlueSense Controls

Demand ventilation solutions.

BlueSense philosophy combines intelligent control technologies with energy saving products, services and engineering expertise. BlueSense helps meet energy reduction commitments by optimising the equipment performance, improving energy efficiency, saving money and increasing equipment life expectancy.

BlueSense can be applied to a variety of projects and applications, providing efficient solutions whilst supporting design for best practice and sustainability.

BlueSense Features

- ▶ Inbuilt intelligent controls technology.
- ▶ Optimises performance and efficiency.
- ▶ Demand ventilation control improves air quality, reducing energy consumption and lowering operating costs.
- ▶ Combined CO₂ and VOC sensing technology with energy efficient speed control.
- ▶ Extending equipment life expectancy and reducing maintenance.
- ▶ Short term payback on capital expenditure.

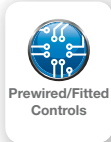

Prewired/Fitted Controls
Factory fitted, pre-wired controls provide packaged solutions reducing the amount of onsite installation and commissioning.



Demand Ventilation
improves air quality, reduces energy consumption and lowers operating cost.



Energy Efficient Fans
and motors reduce energy consumption to help meet current and future Part L Regulations - Specific Fan Power SFP.



Speed Control
Energy efficient speed control forms an integral part of the demand ventilation philosophy.



Air Quality (VOC)
Combined CO₂ and VOC sensor provides demand ventilation information to regulate the required amount of airflow for varying occupancy levels.



'Plug & Play'
technology provides safe and easy customer connections whilst improving the efficiency of production and maintenance.



Energy Monitoring
is an effective way of highlighting area's for potential savings whilst providing a key indicator to ongoing energy consumption.



Filters
Efficient filtering with low pressure drops can significantly reduce the overall life cycle costs of the system, less filter changes and reduce energy consumption.

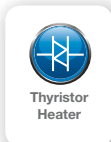

Thyristor Heater
Modulating Thyristor provides accurate and efficient temperate control.



Humidity
Digital control over humidity and temperature levels provides intelligent building solutions.



Heat Recovery
Heating and Cooling recovery reduces the amount of mechanical energy required to maintain system temperatures.



Temperature
Energy efficient temperature control increases occupancy comfort whilst reducing energy waste and saving money.

A BlueSense Example

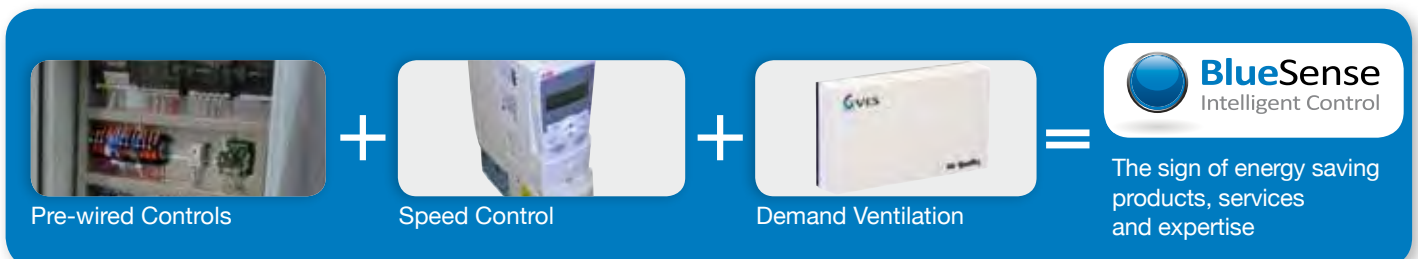

BlueSense Energy Savings

Energy Chart Life Cycle Costs



Energy comparisons for our products illustrate how they reduce energy demands whilst improving the environment and saving money.

The example below is for our Ecovent ventilation units, it shows a typical office building, with an occupancy variation that results in an average 40% reduction in airflow requirement for 40% of the working day. The ventilation system operates from 8am till 6pm, Monday to Friday, with a ventilation rate of 0.55m³/s at 100Pa.

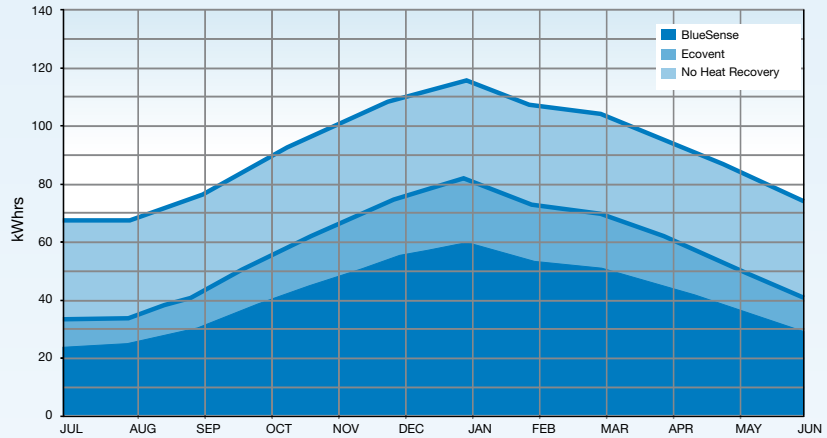

Comparison Of Unit Costs Over 10 Years

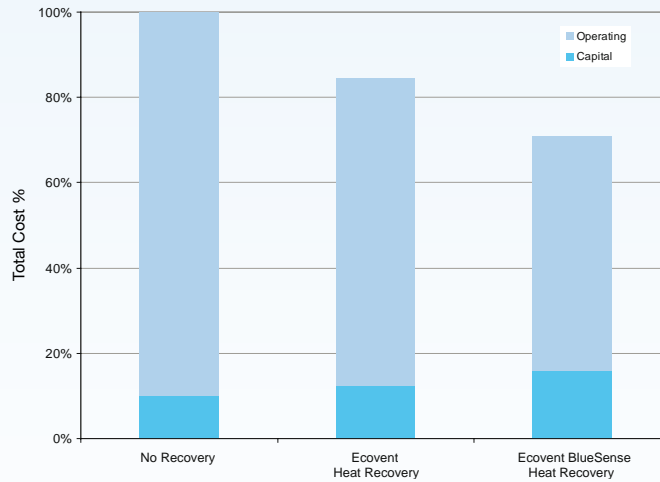

The heating requirement has been based upon the UK heating profile for an air temperature setpoint of 18.5 °C; the same heater size has been used for all comparisons.

Conclusion

Combining VES products with BlueSense technology will reduce the impact to the environment, minimise overall life cycle costs and payback period.

VES is experienced at discussing energy requirements with clients, our knowledge and technology can help to identify areas where savings can be made. VES can provide assistance for both new and existing buildings.



BlueSense
Intelligent Control

BlueSense Includes an Extended Warranty

- ▶ 3 years with BlueSense packages.
- ▶ 5 years with BlueSense package and Post Installation Commissioning.

Please quote BlueSense with your order or contact our specialist sales team for further information. Call +44 (0)8448 15 60 60.

Specials



If you require any more information on the above services please do not hesitate to contact one of our controls experts, who will be more than happy to help.

Tel: +44 (0)8448 15 60 60

VES specialises in meeting customer requirements, working with customers to provide tailored solutions. VES has a wealth of experience, expertise and state of the art technology to ensure that the system operates according to customer needs.

VES Controls division has been operating for over 10 years, providing a range of control panels, from stand-alone applications to fully integrated energy optimising solutions that can communicate on a range of Building Management networks.

Features

- ▶ Fan and motor control.
- ▶ Electric, LPHW, Gas and DX control loops.
- ▶ Close temperature control to accuracies of $\pm 0.1^{\circ}\text{C}$.
- ▶ Heating and cooling recovery via plate heat exchangers, heat wheels, mixing box and run around coils.
- ▶ Humidification/de-humidification.
- ▶ Enthalpy control, energy monitoring and demand ventilation.
- ▶ Communication - Modbus®, BACnet® and TREND®.
- ▶ Wide selection of user and BMS interfaces.

Design Assistance

VES Controls experts can help with a variety of questions. They are experienced at attending consultation and design site meetings, offering advice and expertise up front. This ensures that the system is designed to work from the start; meeting regulatory and customer demands, whilst reducing energy and ultimately saving money.

Post Installation Commissioning

Today's HVAC system must be energy efficient, satisfy stringent indoor air quality and comfort expectations, and still be designed and constructed within tight budgets. Effective HVAC commissioning is an intentional, cooperative and proactive approach that plays an important part in meeting these demands.

The Post-Installation Commissioning by a VES controls specialist provides an essential service to ensure efficient operation of the equipment. This results in significant value to all parties by delivering a system that performs as specified, intended, and paid for.

Benefits to Post-Installation Commissioning from VES offer managed start-up procedures, shorter handover transition, improved air quality and occupancy comfort. Further advantages include more efficient operation and reliability, reduced maintenance, whilst providing lower energy usage and operational cost.

Specify a BlueSense ventilation controls package when selecting an air handling unit from VES, which includes a factory fitted control panel and Post-Installation Commissioning. This provides a 5 year warranty as standard, affirming our long term commitment to operational performance, reliability and safety.

Site Installation

VES can supply HVAC equipment and controls pre-wired and factory commissioned for many applications. Additionally, our service can be expanded to include full site installation. From the main site connection, VES will install the control panel(s) and AHU(s) and electrically interconnect and commission the system. VES can supply the goods and services to provide a complete ventilation package with sensible economics and peace of mind that comes with sourcing a range of experience and expertise from one supplier.

BMS Integration



VES understands that the integration of building services components into a higher level building automation system today is a key factor in building design and meeting energy efficiency requirements. Open protocol systems offer technical advantages, increasing flexibility for the specifier, purchaser and end users, and can provide overall cost reductions.

VES provides a number of communicating protocols including BACnet®, Modbus® and TREND®, allowing fast and simple integration of the HVAC controls onsite, no matter what the building automation and control system is.

Information supplied by the VES packages forms an integral part of the intelligent building automation system and can help reduce the energy consumption of buildings. The lower consumption, and thus increased energy efficiency, significantly reduces operating costs and contributes substantially to climate and environmental protection - without sacrificing comfort.

Communicating solutions allows VES to deliver the complete HVAC package, factory tested and commissioned directly to site, with integration made by the system integrator in a matter of minutes.

BACnet®

BACnet® is a data communications protocol for Building Automation and Controls Networks. It is an ASHRAE, ANSI and ISO protocol. A native, open communication network that is a feature built into the system and requires no effort for hardware, software or service, it is based around standardised objects and services that are widely supported and where conformity has been checked.

Modbus®

Modbus® is a serial communications protocol and one of the most widely used protocols in BMS. VES controllers are able to communicate directly using the Modbus® protocol, using RTU mode; communication standard RS485 and RS232.

TREND®

IQ3 TREND® controllers are Building Management System controllers that use Ethernet and TCP/IP networking technologies. Each controller incorporates a web server which can deliver user specific web pages to a PC or mobile device running the internet browser software. It is also compatible with the traditional TREND® IQ system protocol for the complete Building Management System.

User Interface

Room Controllers



Room Units



Human Machine Interfaces



VES offers a broad portfolio of interfaces comprising simple as well as complex communicating devices. A dedicated interface allows the user to specify the range of functions depending upon application type, not limiting the choice based upon air handling model.

Interfaces can be either a stand-alone room unit or connected to others creating tailored solutions for demanding applications. They cover a wide range of different heating, cooling and ventilation applications, addressing individual customer needs.

LCD room controller, with built in application processor provides adjustable commissioning and control parameters for simplistic HVAC applications.

- ▶ The LCD room unit is very versatile, comprising a large display and intuitive operating concept with setting knob and large buttons.
- ▶ Extremely user-friendly and the backlit display allows the unit to be operated in the dark.
- ▶ The required application and parameter settings can simply be selected via DIP switches before mounting the unit.
- ▶ The room unit uses the built in room temperature for 2 position P (Proportional) or PI (Proportional-Integral) algorithms.
- ▶ Built temperature sensor and 7 day time clock.
- ▶ Numerous energy saving features include comfort and economy mode, sensor calibration and set point limitations, control loop adjustments and button lock for setting protection.

VES provides a variety of room units to meet every requirement, from simple On/Off to more complex unit with extensive features and adjustments.

- ▶ Easy to understand symbols, optional LCD display as well as large keys and adjustment knobs are just a few features to ensure straight forward operation.
- ▶ Energy-efficient and cost saving control can be accomplished by time based schedules, comfort levels and PID (Proportional-Integral-Derivative) tuning.
- ▶ Simple operation and high control accuracy for optimal comfort and ease of use.
- ▶ Fast and easy installation and commissioning.
- ▶ High quality products, consistent feel and look, providing individual or multi-zone control.

VES offers touch screen HMI's (Human Machine Interface) for a comprehensive way to display and adjust important information from your factory-mounted controllers.

We provide standard solutions that comprise a 3.4" mono or 3.8" colour touch screen, however these screens are fully customisable and can be supplied up to 15" for complex applications, if required.

- ▶ Suitable for internal or external, room or panel mounting.
- ▶ Defined password levels.
- ▶ Sensor display and measurement for given application - Temperature, Humidity, Pressure, Air Quality.
- ▶ Control adjustments; setpoint, fan speed, PID control loop, detailed alarm management.
- ▶ Plant schematic, trending and data analysis.

Sensors



Air Quality



Temperature



Room Humidity

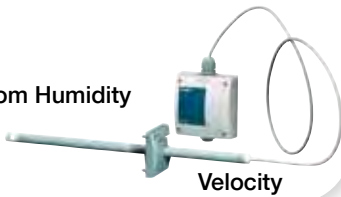

Velocity

VES provide a wide range of measurement sensors for a variety of applications, providing an optimal base for precise and therefore energy and cost-saving control of the entire HVAC system.

Features

- ▶ Temperature, Humidity, Air Quality, Velocity and Pressure.
- ▶ Wide choice of products covering all installation environments.
- ▶ Innovative designs for simple installation.
- ▶ High degree of accuracy and reliability for extended life cycle and long term stability.

Speed Controllers

3 Phase Inverter Speed Control



IP21



IP54

VES offer a range of speed control options to suit fan-motor and application requirements. All our speed control options can be provided loose for wall mounting or incorporated within the overall controls package or air handling unit - reducing the need for site installation and commissioning.

Inverter

IP54 with comprehensive functions:

- ▶ Complete with standard operational key pad or optional advanced key pad with built-in time clock.
- ▶ IP54 protection for indoor or external use.
- ▶ Features include BMS control, remote manual controller, temperature, constant pressure, humidity and CO₂/VOC control.
- ▶ Main isolating switch with lockable handle.
- ▶ Panel live switch with lockable handle.
- ▶ Damper control.
- ▶ Volt free run and trip indication.
- ▶ Easy customer installation.

Low cost IP21:

- ▶ Complete with operational key pad.
- ▶ IP21/NEMA1 protection for indoor use.
- ▶ Features include On/Off control at inverter key pad and manual controller available (CFSC1) for remote speed adjustment.

Traditional Speed Controllers

1 phase: Manual

- ▶ Tapped transformer type in five steps and Off, or electronic variable speed type.

1 phase: Automatic

- ▶ The MS 10 speed controller will modulate providing automatic fan speed control via a 0-10Vdc signal from BMS, eg Air Quality or Temperature sensor.

3 phase: Manual

- ▶ Tapped transformer type in five steps and Off, or electronic variable speed type.

Features Cont.



Cooling

Chilled Water,
DX Stepped
or Modulated Heatpump,
De-humidification.

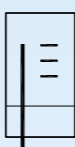

Humidifier

De-humidifier



Filters

Pre-Filter,
High Grade Main Filter,
Extract Filter,
UV Filter.

Pressure Switches to provide
remote indication.

Pressure transducer to
provide remote mapping.



Dampers

Inlet / Outlet,
Mixing Box,
Face and Bypass Damper,
Duct Leg.

Control Panel Location

Wall Mounted,
Integral to AHU.
User / Supervisor
Room Control.

On-Site Assistance

Sales Support.
Commissioning.
Post Installation.



Air Flow
Pressure Switch



Temperature
Sensor



Electrical
Heating



3 Port Valve
& Actuator



Heatpump



2 Port Valve
& Actuator



Switch



Motor/Actuator



Thyristor
Heating
Control



Humidity
Sensor



7 Day Time
Clock

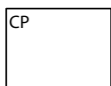

Control
Panel



Save **energy** and costs with **BlueSense** Controls

BlueSense philosophy combines intelligent control technologies with energy saving products, services and engineering expertise. BlueSense helps meet energy reduction commitments by optimising the equipment performance, improving energy efficiency, saving money and increasing equipment life expectancy.

BlueSense can be applied to a variety of projects and applications, providing efficient solutions whilst supporting design for best practice and sustainability.



Filters



Demand Ventilation



Heat Recovery



Prewired/Fitted Controls



Air Quality



Thyristor Heater



Energy Efficient Fans



Speed Control



Plug & Play



Humidity



Temperature



Energy Monitoring

Tel: 08448 15 60 60

www.ves.co.uk



BlueSense
Intelligent Control

Other products and services from the complete range of VES HVAC solutions:

Air Handling Units:

- Supply and extract, combined or separate.
- Heat recovery including crossflow plate heat exchangers, thermal wheel, run-around coils.
- Plantroom or weatherproof, flat or stacked.
- Fitted silencers, fitted inverters and controls.
- Matching DX condensing units.
- Various case constructions including EN 1886 certified units.

Duct Fans:

- In-line centrifugal, with forward or backward curved impellers.
- Round fans, axial and mixed flow fans.
- Fitted silencers available all units.
- Manual and automatic speed controllers available.

Twin Fans:

- For ceiling void, plantroom, and weatherproof.
- Many models and configurations.
- Fitted auto-changeover system.

Roof Extract Units:

- Three ranges for volume and pressure.
- Curb and soaker sheet bases.

Wall and Ceiling Fans:

- All types for commercial, industrial and domestic premises.

Kitchen Hood Extract Fans:

- Heavy duty high temperature fans for hot greasy air.
- Motors out of airstream.
- Single inlet fans, in-line and vertical jet roof units.

Control Panels:

- Off the shelf and built to order panels.
- Air quality sensors and energy savers.
- Intelligent control software.
- A range of remotes including touch screen.

Noise Control:

- Matching silencers available for all ventilation products.
- Silencers designed to meet noise criteria.
- Cleanable silencers.
- Weatherproof silencers.

Specialist Site Services:

- Plant refurbishment.
- Energy saving upgrades.
- Noise reduction.
- Site surveys.
- Kitchen ventilation.
- AHU flat pack installation.
- Maintenance.
- Spares.



Buy from
VES Direct
www.vesdirect.co.uk

© 2011 VES
 Issue CO01 - 06/2011

VES reserve the right to amend product specifications and details without notice.



ISO 9001:2008
 Cert. No. Q05375

