



SAM & REX

Installation, Operation and Maintenance Manual

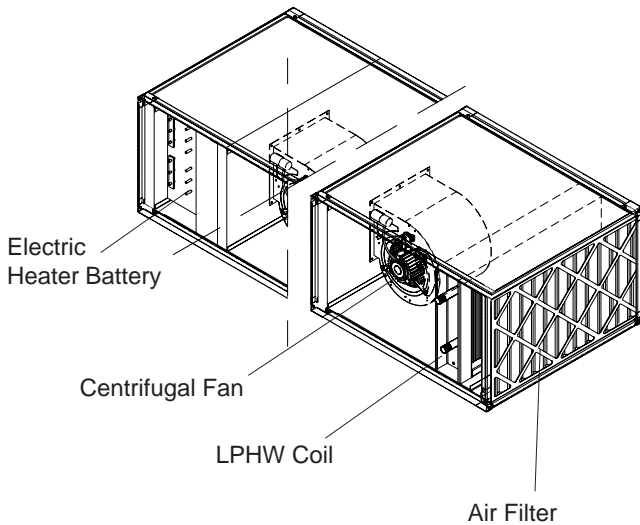

Fig.1 Typical unit layout
 (SAM Unit shown with side door removed)

IMPORTANT !

This manual must be read in full before Installation, Operation and Maintenance of the equipment supplied

Contents		page
1	Introduction	1
2	Receipt of Goods/Handling	1
3	Installation	1
4	Wiring	3
5	Maintenance	5
6	Warranty	6
7	Declaration of Conformity	7

1 Introduction

The SAM (Small Air Movers) are ideal for installation in commercial and public buildings, with five sizes of unit and a duty range of up to 2.4m/s. The range offers single or double skinned cases, with an extensive range of options. Components are removable from one side, facilitating maintenance and wiring. Standard operating temperature of the unit is -20 to +35°C.

For further technical details regarding dimensions and weights, contact VES on **08448 15 60 60**, quoting the sales order (SO) number and the unit type as found on the unit nameplate or visit **www.ves.co.uk**.

2 Receipt of Goods/Handling

Immediately upon receipt of goods check for possible damage in transit, paying particular attention to fan impeller, motor and flexible connections.

Prior to installation please check to ensure smooth rotation of the impeller after transit. Also check to ensure that any ancillary items are included. These will normally be supplied fitted or in the case of small items, taped to the unit.

In the event of any damage having occurred or if any item is found missing, it is essential to inform VES Andover Ltd. within **3 working days** of delivery quoting sales order (SO) number and the unit type as found on the unit nameplate. After this period we will be unable to accept any claim for damaged or missing goods.

IMPORTANT !

This unit should NOT be lifted by its coil connections

3 Installation

The entire system must be considered for safety purposes and it is the responsibility of the installer to ensure that all of the equipment is installed in compliance with the manufacturer's recommendations, with due regard to the current HEALTH AND SAFETY AT WORK ACT and conforms to all relevant statutory regulations.

Where a unit is installed so that a failure of components could result in injury to personnel, precautions should be taken to prevent such an injury.

If the unit is installed where there is a reasonable possibility of persons or objects coming into contact with the impeller, a guard should be fitted.

IMPORTANT !

Only experienced fitters should undertake this work. Take necessary safety precautions when working in elevated positions

It is the installer's responsibility to ensure that access panels are not obstructed in any way and safe working access for maintenance must be provided.

For optimum unit performance, careful consideration must be paid to the location of the unit in relation to the ductwork and associated items; placing the unit directly adjacent to a bend in ductwork will impede airflow and reduce performance. Consideration must also be given by the installer for adequate illumination of the unit's location in order for safe maintenance. Where provided, flanges and spigots should not be used to support the ductwork and used solely as a means of ductwork connection. Further consideration should be given to the unit's position and secured into place as appropriate, failure to do so may effect the overall stability of the unit.

The SAM/REX units and silencer are designed to fit directly to proprietary 20mm MEZ flanges. Silencers are supplied loose. Ensure that they are fitted to the correct end of the unit, and the right way round. Flexible connections, AV mounts and mounting feet are not supplied fitted to the unit, but are easily assembled using the fastenings supplied. The SAM5 and REX5 units have internal AV mounts and flexible connections pre-fitted to the fan.

All components with the SAM and REX size 1-4 units are mounted on sliding trays for ease of maintenance. The SAM5 and REX5 components are not fitted onto sliding trays, but are easily accessible.

SAM and REX cases size 1-4 have access handing to the left or right of the unit. To flip the component access handing to the opposite side, the whole unit can be rotated 180° through the length of the case. After rotation, the slide in components will be upside down.

Withdraw the component trays, then replace them in the correct orientation.



SAM & REX

Installation, Operation and Maintenance Manual

3 Installation (Continued)

IMPORTANT !

Should it be necessary to remove/replace any slide-in components, it is critical that they be refitted correctly by a competent engineer

Mounting the unit

All centrifugal fan units must be installed with the fan/motor shaft in a HORIZONTAL position. (See Fig.2)

For alternate mounting positions, please contact our customer services department on **08448 15 60 60**.

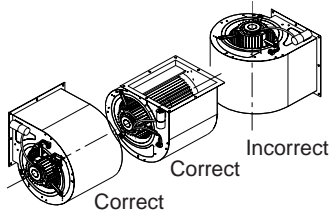

Fig.2 Standard fan mounting orientation

Inlet and Outlet duct connections

Ducting should always be independently supported to avoid distorting fan unit casing. Flexible connections should always be used to reduce vibration transmission.

Before running the fan, check that nothing is obstructing the free running of the fan impeller.

Units SAM/REX48-1 must have at least 100Pa operating pressure, and SAM/REX59-1 must have at least 200Pa. If these conditions are not available, an iris damper must be fitted to the fan, or the system adjusted appropriately.

Hot Water Coils

On the SAM-W unit, a Low Pressure Hot Water (LPHW) coil will be installed (See Fig.3). The coils are normally suitable for LPHW at 82°C flow and 71°C return temperature. LPHW coils should have an air vent and drain plug located on the pipe work immediately adjacent to the AHU; they are not fitted to the coil.

The air vent should be at the highest point, with the drain at the lowest. When the coil is at a high point of the system it should be regularly vented so as to avoid potential air locks, resulting in a fall off of duty.

It is important that water and steam coils are protected against damage from extreme weather conditions during the winter season.

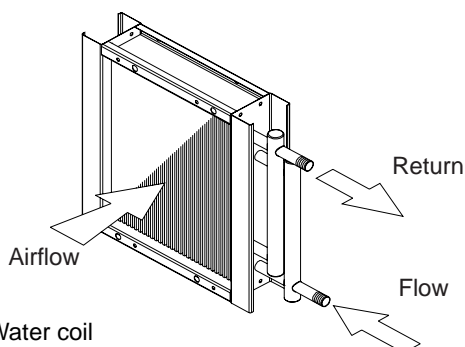

Fig.3 Water coil

If the water is allowed to freeze in the coil system, damage may occur potentially bursting pipes and resulting in emergency problems.

This can be prevented by fitting a frost thermostat at the unit inlet and ensuring that boilers run continuously in low ambient temperatures.

Heating coils do not cool immediately when the hot water supply is cut off. The residual heat must be dissipated to avoid damage. The continuous running of the fan after shutdown resolves this, by operation of a run-on timer.

The recommended length of run-on is two minutes minimum.

It is recommended that a check be made as to whether any treatment is required to the water supply for prevention of corrosion and scaling of the equipment. Information regarding the necessary action to be taken can be obtained from the relevant Water Supply Authority.

We recommend that the LPHW coil connections of the SAM unit are ordered on the opposite side to the fan and filter access panels. Should they be on the same side, do not locate pipe work to the heating coil in front of access panels, which will prevent access and filter removal.

Steam Coils

Steam coils (See Fig.4) are suitable for use with saturated steam up to 100psi. The pipework must be so arranged to provide adequate drain lines with a suitable strainer and steam trap. All steam and drain lines should be lagged. The supply should be taken from the top of the steam main, to avoid the introduction of moisture or air into the coil. The pipe shall be arranged so that it does not interfere with the coil expansion. Where steam coils are fitted it is essential that a time delay is installed in the fan starter control circuit.

The fan shall be kept running for at least two minutes after the steam supply to the coils has been shut off, so that residual heat of the coil is dissipated.

If the pipe run is unduly long and prone to water logging, it should be properly trapped, just before the coil. If the steam is from a high pressure steam main, it is essential to have a working pressure relief valve on the low side to ensure that dangerous overheating of the air and excessive pressure cannot occur.

We recommend that the steam coil connections of the SAM unit are ordered on the opposite side to the fan and filter access panels. Should they be on the same side, do not locate pipe work to the steam coil in front of access panels, which will prevent access and filter removal.

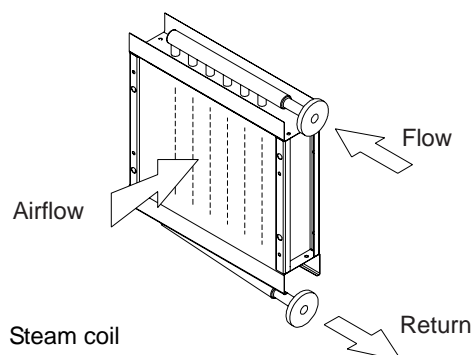

Fig.4 Steam coil



SAM & REX

Installation, Operation and Maintenance Manual

3 Installation (Continued)

DX Coils

DX and Condenser Coils (See Fig.5) must be connected to systems in accordance with accepted refrigeration codes of practice and if fitted upstream to steam or water coils, care must be taken to ensure that the air temperature does not drop below 0°C

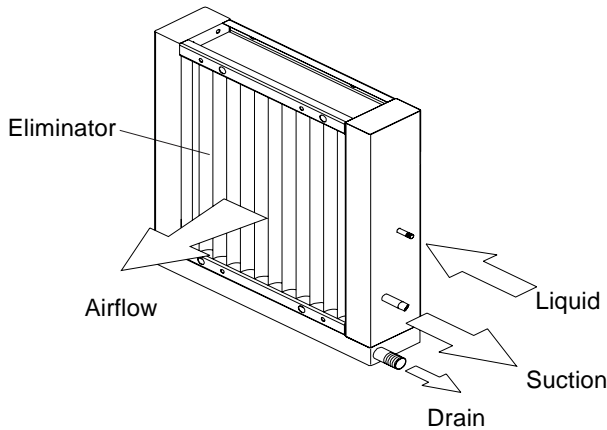

Fig.5 DX and Condenser Coil Connections

Electric Heater Batteries

Supply to the heater should be 1ph or 3ph with separate neutrals; confirmation of this can be found on the unit nameplate. Cables should be of silicone rubber, fibreglass or of a similar high temperature insulated type and be installed to current I.E.E. Regulations, ensuring a sufficient earth connection to the terminal provided. Care should be taken not to overstrain the terminal pillars as this may permanently damage the elements.

The heater is fitted with a manual reset high temperature cut-out with normally closed (NC) terminals.

IMPORTANT !

The cut-out is set to break if the duct temperature rises above 130°C and must be connected in series with the main contactor coil circuit if the heater is to be isolated in the event of overheating.

In the event that the cut-out should be activated, it is recommended that this be replaced. For further details, see Maintenance section on page 5

The electrical supply must be isolated before attempting to reset the manual cut-out.

In order to prevent overheating within the unit, a 2-5 minute fan run-on timer should be incorporated into the control circuit. This will prevent any excessive build up of heat within the AHU and avoid damage to those internal components that could result in such an event.

IMPORTANT !

It is essential that all electrical connections are properly made

The elements are tested prior to dispatch and are within a tolerance of 7.5W. In the event that elements should be found to be faulty they can be easily removed and replaced. To remove the electric heater battery, take out the fixings from the element tray and slide the assembly free.

Elements that are stored in damp conditions may need drying to attain correct insulation readings.

For further technical details contact **VES Customer**

Services Department, quoting the sales order (SO) number and the unit type as found on the unit nameplate.

Fan Speed Controllers & EHBs

If a speed controller is fitted to the system, it must not stop the fan independently of the control system, or allow airflow to fall below the stated volume on the electric heater battery.

Suitable speed controllers without on/off switches are available from VES Andover.

Thermal Cut-out

Where both manual and automatic thermal cut-outs are fitted, they should be connected in series with the operating coil of the controlling contactor which will switch off the heater when the cut-out trips. It should also have a warning lamp in the control system, as it will reset when temperature falls below 85°C.

Connections

20mm conduit holes are provided for incoming cables.

N.B. Terminal pillars are fitted to element studs. Care should be taken not to strain studs, which will damage elements permanently. Always fit an isolator for maintenance of heater.

Where provided, flanges and spigots should not be used to support the ductwork and used solely as a means of ductwork connection. Further consideration should be given to the unit's position and secured into place as appropriate.

4 Wiring

IMPORTANT !

Electrical supply must be fully isolated before attempting to affect any work on this unit

When making mains power connections, ensure that appropriate cable strain relief is used and that internal cable looms are securely stowed to minimise the possibility of cable abrasion.

All electrical connections to any unit must be carried out in accordance with the current edition of the I.E.E REGULATIONS and only competent Electricians should be allowed to affect any electrical work to our units.

IMPORTANT !

Do not connect any unit to an electrical supply voltage outside of the specification

The following wiring diagrams are a guide to installing the standard fan and actuator options found on the SAM and REX units. Refer to Figures: 6-9

If in any doubt, or for special versions of the units, consult the wiring diagram in your document pack or contact our customer services department on **08448 15 60 60**, quoting the sales order (SO) number and unit type as found on the unit name plate.

A trial connection of the three phase supply should be made to check that the fan rotates in the correct direction as indicated on the fan. If the rotation is incorrect, interchange any two phases of the incoming supply at the terminal block.

For incorrect rotation of single phase fans, check with the VES Service department for advice, on **08448 15 60 60**.



SAM & REX

Installation, Operation and Maintenance Manual

Fig.6
 230V 1 Ph 50Hz
 SAM/REX11 only

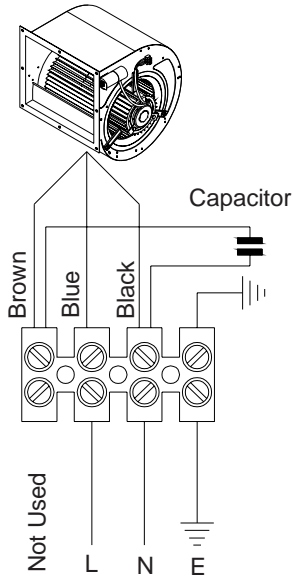

Fig.7
 230V 1 Ph 50Hz
 SAM/REX12,23,24,26,35,36,37,48-1, 59-1

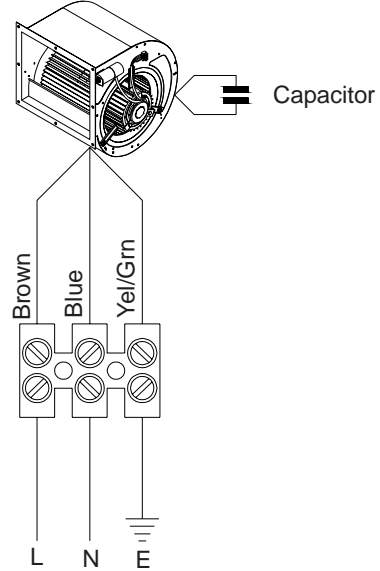
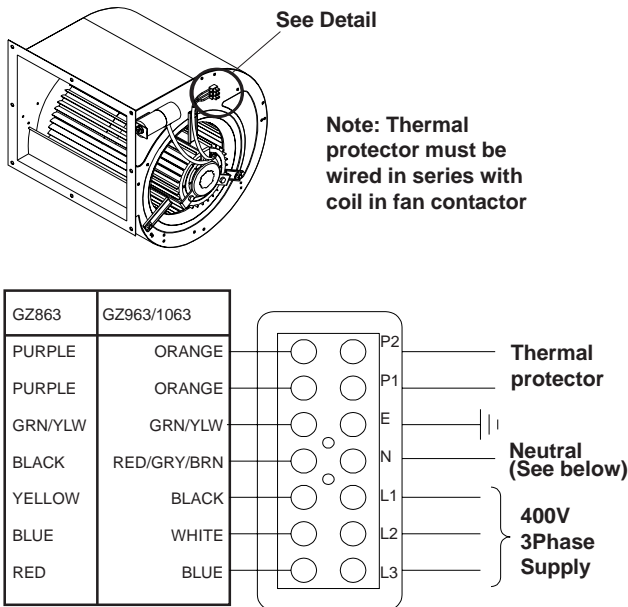
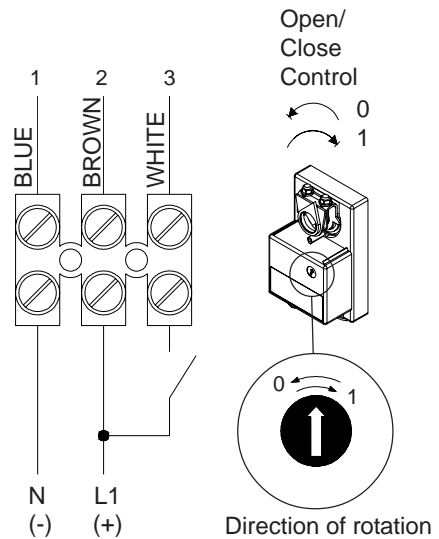

Fig.8
 400V 3 Ph 50Hz
 SAM/REX48-3,59-3 and 510-3



Neutral MUST be used when SC310 or SC310E speed controller is fitted

Fig.9 Damper actuator wiring arrangement
 230V 1Ph 50Hz
 (24V 1 Ph 50Hz)



NM230A/NM24A Damper Actuator

To isolate from the main power supply, the system must incorporate a device which disconnects the phase conductors

To identify your fan, please check your unit model code against the replacement fan index on page 5.



SAM & REX

Installation, Operation and Maintenance Manual

5 Maintenance

IMPORTANT

Before attempting to carry out any maintenance work, investigative or repair work on our units, the unit **MUST BE COMPLETELY ISOLATED** from its electrical supply. Ensure a minimum of two minutes after electrical disconnection before removing access panels. This will allow any moving parts to come to a rest

In general, this series of units require very little maintenance. In the unlikely event of component failure, spares are available from stock at VES Andover Ltd.

IMPORTANT

Before attempting to carry out any work on our units, all accompanying documentation including warning labels on the unit must be referenced

Recommended check

In order to keep the unit in good order the following maintenance routine is recommended:

Three Monthly Check

Filters should be inspected every three months. If they are found to be heavily soiled or damaged in any way they should be replaced.

Six Monthly Check

The fan impeller should be cleaned every 6 months. Withdraw the fan as far as possible from the SAM or REX case, then carefully clean with a vacuum cleaner and brush. Failure to clean the fan on a regular basis could result in loss of fan performance, or cause it to fall out of balance.

Dampers can be afforded some protection by pre-filtration. If required, clean blades, cogs and frames and lubricate with PTFE aerosol or equivalent. Failure to keep dampers clean could result in the damper becoming jammed.

Twelve Monthly Check

SAM and REX units are supplied with both unpainted galvanised sheet steel cases and powder coat paint finish. Every 12 months, check all painted items to ensure that they have not deteriorated, particularly where adverse environmental conditions prevail. Re-paint as necessary. Paint can be supplied upon request.

IMPORTANT

It is critical that after any maintenance work has been conducted that all components removed/replaced be refitted correctly by a competent engineer

Spares and Repairs

All of this series of units have a long life expectancy. Spares or direct replacements using improved components, are normally "off the shelf" and all fans will be held in stock for a minimum of 10 years.

We recommend however that a spare motor and impeller kit are held for those units installed in critical areas, or for units that need to run on a continuous basis. To obtain a motor and impeller kit, please advise our service department of the Sales Order (SO) Number and type of fan unit for which the kit is required. This can be obtained from the unit name plate.

Recommended Spares.

A list of spares recommended to be held by the user of a specific unit is available if required.

Electric Heater Elements

Advise our Sales Department of unit size, kW rating of EHB and Works Order Number from label on fan access panel.

High Temperature Cut-Out

Part No. EHEX1010.

Control Panel and Speed Controllers

Contact VES Customer Services Department with Model Number and Works Order Number.

Replacement Filters

Standard Panel Filters

SAM/REX MODEL	FILTER SIZE (mm)	VES PART NO.
1	550 x 270 x 50	SAMDF1
2	700 x 425 x 50	SAMDF2
3	800 x 495 x 50	SAMDF3
4	900 x 595 x 50	SAMDF4
5	695 x 595 x 100 (2 No.)	SAMDF5

Replacement Fans

Example. SAM11-Size1 = GZ141
REX510-3 Size10 3 Phase = GZ1063

FAN SIZE	FAN MODEL NUMBER
1	GZ141
2	GZ241
3	GZ361
4	GZ461
5	GZ561
6	GZ641
7	GZ741
8-1 phase	GZ861
8-3 phase	GZ863
9-1 phase	GZ961
9-3 phase	GZ963
10-3 phase	GZ1063

Standard LPHW Coil

SAM MODEL	COIL REFERENCE
1	SAMCL1010
2	SAMCL1020
3	SAMCL1030
4	SAMCL1040
5	SAMCL1050

WEEE Directive



At the end of their useful life the packaging and product should be disposed of via a suitable recycling centre.

Do not dispose of with normal household waste.
Do not burn.

When enquiring after or ordering spares contact VES Spares Department, quoting the sales order (SO) number and unit type as found on the unit nameplate.

Telephone 08448 15 60 60
Fax 023 8026 1204



PLEASE ENSURE THAT THIS DOCUMENT IS PASSED ON TO THE END USER.

We reserve the right to alter the specification without notice

©VES Andover Ltd. 2007

No part of this publication may be photocopied or otherwise reproduced without the prior permission in writing of VES Andover Ltd.



SAM & REX

Installation, Operation and Maintenance Manual

6 Warranty

Extended Warranties

All VES Andover Products come with a one year guarantee from date of dispatch, which covers parts and labour. You can now extend this with the following options:

Option 1. FREE extended Warranty

We can offer you a maintenance agreement that keeps this equipment in tip-top condition. If you take out this agreement, we will extend the warranty **free of charge for up to 5 years**, providing the regular maintenance agreement remains in place.

Option 2. 12-24 Month Extended Warranty

12-24 months from the date of dispatch. This can be covered at a cost of just 3% of order value. (Minimum charge £50.00).

Option 3. 12-36 Month Extended Warranty

12-36 months from date of dispatch. For this cover, the charge is 6% of order value (minimum charge £80)

Please State which option you require when you place your order. A transferable certificate will then be issued to you. *Please note, this offer excludes condensing units. We would be happy to quote you for these separately.*

Register for separate spares reminders and get a 10% discount

Register for this free service and we will automatically send you a regular reminder detailing the consumable spares for this unit, together with their current list prices.

You will then be entitled to a 10% discount off any spares.

To arrange any of these options.

Phone: 08448 15 60 60
Or Email: spares@ves.co.uk

Stating the sales order and reference number from the unit.



SAM & REX

Installation, Operation and Maintenance Manual



Declaration of Conformity

Date: Date Month 2006

Product: SAM and REX

Type: Small Air Movers

Manufacturer: VES Andover Limited

The product above is produced in accordance with EC Council Directives:

98/37/EC (Machinery Directive)

89/336/EEC and amendment 92/31/EEC (Electromagnetic Compatibility Directive)

73/223/EEC and amendment 93/68/EEC (Low Voltage Directive)

The European Harmonised Standards applied are:

BS EN ISO 12100, EN 294, EN61000, EN 60204-1

The National Standards applied in particular are :

BS 848 Part 1

Basis of Self attestation:

Quality Assurance to ISO 9001-2000, BSI Reg. Firm Cert. No. Q5375

Signature of Manufacturer:

Position of Signatory:

Technical Director