



Centrifume - CFR Units

Installation, Operation and Maintenance Manual

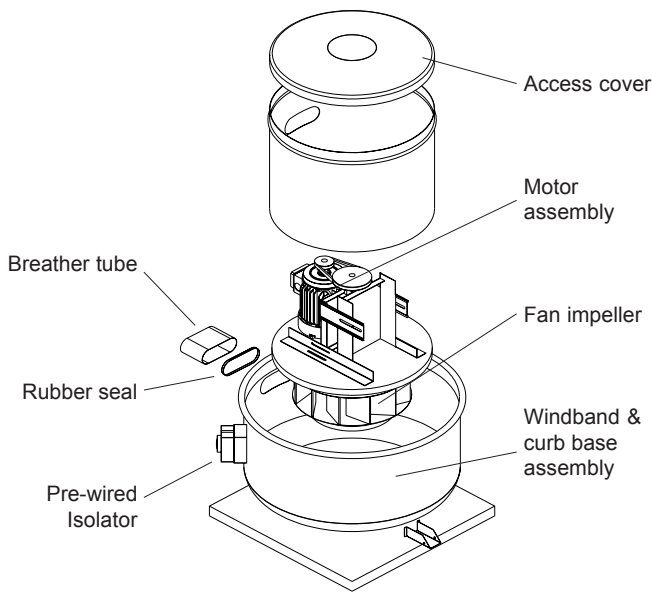



Fig.1 CFR Exploded view

IMPORTANT 
 The unit should NOT be lifted by handles, lids, housings, shaft, motor or drive.

When moving the unit, handle with care and in such a manner as to avoid damaging the casework. Units are to be rigged and lifted using spreaders, taking into account the weight of the unit, and lifting gear should be arranged so as not to bear on the casework.

3 Installation

IMPORTANT 
 Only experienced fitters should undertake this work.

The entire system must be considered for safety purposes and it is the responsibility of the installer to ensure that all of the equipment is installed in compliance with the manufacturer's recommendations, with due regard to the current HEALTH AND SAFETY AT WORK ACT and conforms to all relevant statutory regulations. Where a unit is installed so that a failure of components could result in injury to personnel, precautions should be taken to prevent such an injury.

It is the installer's responsibility to ensure that safe working access to the unit for maintenance is provided. Consideration must also be given by the installer for adequate illumination of the unit's location in order for safe maintenance.

For optimum unit performance, careful consideration must be paid to the location of the unit in relation to the ductwork and associated items. Placing the unit directly adjacent to a bend in ductwork will impede airflow and reduce performance; *fig. 2* indicates the recommended installation for a CFR unit.

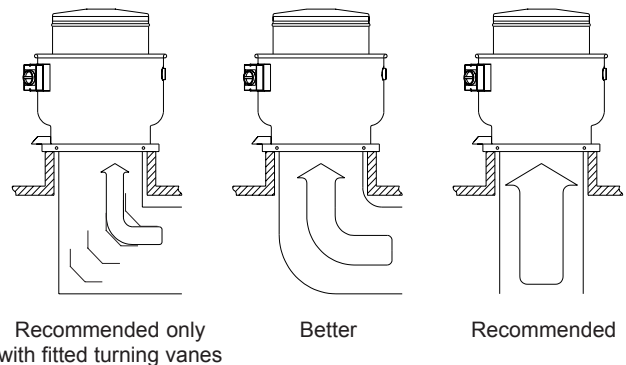



Fig.2 Recommended installation

The CFR unit must be secured to the curb upstand, using the eight pre-punched holes around the edge of the curb base. The upstand must be a minimum of 200mm high if an optional grease collection trough is to be fitted. If the unit does not include a drain trough the upstand height can be lowered. (see *fig. 3*). Consideration should be given to the units mass and the curb upstand should be so constructed as to be load bearing to at least this weight. The top of the curb upstand should be horizontal and flat.

IMPORTANT 
 This manual must be read in full before installation, operation and maintenance of the units supplied

Contents		page
1	Introduction	1
2	Receipt of Goods/Handling	1
3	Installation	1
4	Set-up	2
5	Wiring	2
6	Maintenance	6
7	Warranty	7
8	Declaration of Conformity	8

1 Introduction

The CFR Centrifume is a range of roof mounted, belt driven extract fans, designed to meet the arduous conditions found in restaurant kitchen hood extract systems - hot air with high grease content. The standard ambient operating temperature of the unit is -20 to +35°C, with in-duct airflow up to 190°C.

For further technical details contact VES on **08702 404340**, quoting the sales order (SO) number and the unit type as found on the unit nameplate or visit **www.ves.co.uk**.

2 Receipt of Goods/Handling

Immediately upon receipt of goods, check for possible damage in transit, paying particular attention to fan impeller, motor and drive belts. Prior to installation please check to ensure smooth rotation of the impeller after transit.

Also check to ensure that any ancillary items are included. These will normally be supplied fitted or taped to the unit (in the case of small items). In the event of any damage having occurred or if any item found to be missing, it is essential to inform VES Andover Ltd. within **3 working days** of delivery quoting sales order (SO) number and the unit type as found on the unit nameplate. After this period we will be unable to accept any claim for damaged or missing goods.

Centrifume - CFR Units

Installation, Operation and Maintenance Manual

3 Installation continued

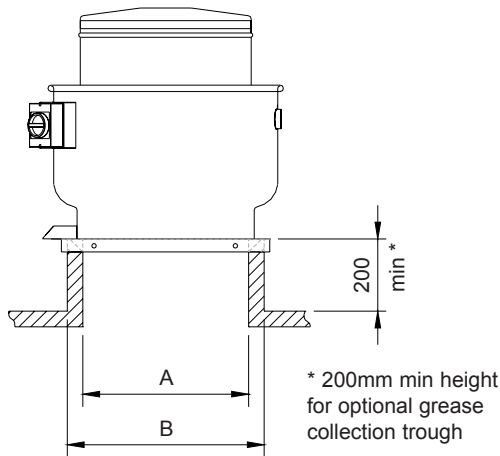

Model	A	B	Weight kg
100/STD	343	445	30
120/STD			31
140/STD	522	622	35
140/HP			40
160/STD			62
160/HP			70
180/STD	570	720	62
180/HP			70
200/STD	670	820	84
200/HP			84
220/STD			130
220/HP			130
240/STD	820	970	130
240/HP			130
300/STD	985	1135	190
300/HP			190
360/STD			190

Fig.3 Recommend curb dimensions (in millimetres)

4 Set-up

Motor and electrical details must be checked prior to connection to electricity supply. All motor information can be found on the unit data sheet supplied attached to the unit.

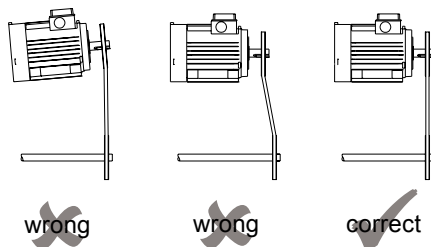

Fig.4 Pulley alignment

Ensure correct pulley alignment as indicated in fig.4 above. To check the tension of the drive belt apply a force perpendicular to the centre of the belt span sufficient to deflect the belt 16mm for every metre of span length, as indicated in fig.5. The force required to deflect the belt should be from 1.5 to 2.0kg.

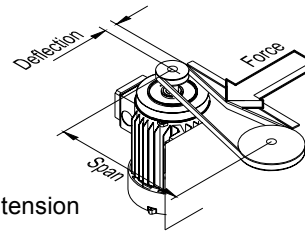

Fig.5 Belt tension

After the drive alignment has been completed rotate the impeller, taking care of the moving parts. If the fan makes a scraping noise or vibrates excessively it may have moved during transit. If this has occurred, re-alignment of the impeller and inlet eye will be necessary. Remove the access cover and loosen off the four retaining bolts indicated in fig.6. Reposition the impeller/motor assembly so that the impeller is free-running and tighten the retaining bolts to secure the assembly into place. Recheck & adjust the drive alignment if required (see fig. 4 & 5)

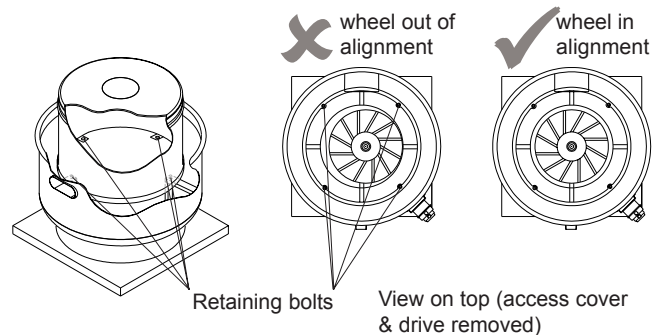
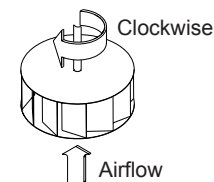

Fig.6 Re-aligning the fan.

Loosen off the four bolts and align the wheel so that it does not touch the casing

Always make sure that the fan is rotating in the correct direction. Direction of flow is indicated on the unit.

Fig.7 As Viewed from above - correct rotation of the impellor



5 Wiring

IMPORTANT !

Electrical supply must be fully isolated before attempting to affect any work on this unit

The CFR Centrifume units comprise a single inlet backward curve fan powered by a belt driven assembly, terminated by a local isolator.

All electrical connections to any unit must be carried out in accordance with the current edition of the I.E.E REGULATIONS and only competent Electricians should be allowed to affect any electrical work to our units.

IMPORTANT !

Do not connect any unit to an electrical supply voltage outside of that indicated on the motor nameplate.

Mains cables should be suitably sized see fig. 8 & 9 and terminated as shown on the appropriate wiring diagram (see fig.10). All standard units are supplied pre-wired to a local isolator. Ensure that suitable strain relief (ie: cable gland) is fitted to the mains supply as appropriate.



Centrifume - CFR Units

Installation, Operation and Maintenance Manual

5 Wiring continued

Fig. 8 Standard electrical details • Three Phase 400V 50Hz

3 Phase Motor Details					
Model	Fan RPM	Motor size (kW)	Motor RPM	FLC**	SC*
CFR100/STD/1000-3	1000	0.18	1330	0.60	1.38
CFR100/STD/1100-3	1100	0.18	1330	0.60	1.38
CFR100/STD/1200-3	1200	0.18	1330	0.60	1.38
CFR100/STD/1300-3	1300	0.18	1330	0.60	1.38
CFR100/STD/1400-3	1400	0.18	1330	0.60	1.38
CFR100/STD/1500-3	1500	0.25	1340	0.70	2.24
CFR100/STD/1600-3	1600	0.25	1340	0.70	2.24
CFR100/STD/1700-3	1700	0.37	1370	1.18	3.89
CFR100/STD/1800-3	1800	0.37	1370	1.18	3.89
CFR100/HP/1300-3	1300	0.18	1330	0.60	1.38
CFR100/HP/1500-3	1500	0.18	1330	0.60	1.38
CFR100/HP/1700-3	1700	0.18	1330	0.60	1.38
CFR100/HP/1900-3	1900	0.25	1340	0.70	2.24
CFR100/HP/2100-3	2100	0.37	1370	1.18	3.89
CFR100/HP/2300-3	2300	0.37	1370	1.18	3.89
CFR100/HP/2500-3	2500	0.55	1400	1.60	5.76
CFR120/STD/700-3	700	0.18	1330	0.60	1.38
CFR120/STD/800-3	800	0.18	1330	0.60	1.38
CFR120/STD/900-3	900	0.18	1330	0.60	1.38
CFR120/STD/1000-3	1000	0.18	1330	0.60	1.38
CFR120/STD/1100-3	1100	0.18	1330	0.60	1.38
CFR120/STD/1200-3	1200	0.18	1330	0.60	1.38
CFR120/STD/1300-3	1300	0.25	1340	0.70	2.24
CFR120/STD/1400-3	1400	0.25	1340	0.70	2.24
CFR120/STD/1500-3	1500	0.37	1370	1.18	3.89
CFR120/STD/1600-3	1600	0.37	1370	1.18	3.89
CFR120/STD/1700-3	1700	0.55	1400	1.60	5.76
CFR140/STD/700-3	700	0.25	1340	0.70	2.24
CFR140/STD/800-3	800	0.25	1340	0.70	2.24
CFR140/STD/900-3	900	0.25	1340	0.70	2.24
CFR140/STD/1000-3	1000	0.25	1340	0.70	2.24
CFR140/STD/1100-3	1100	0.37	1370	1.18	3.89
CFR140/STD/1200-3	1200	0.37	1370	1.18	3.89
CFR140/STD/1300-3	1300	0.55	1400	1.60	5.76
CFR140/STD/1400-3	1400	0.55	1400	1.60	5.76
CFR140/STD/1500-3	1500	0.55	1400	1.60	5.76
CFR140/STD/1600-3	1600	0.75	1410	2.20	9.68
CFR140/STD/1700-3	1700	1.10	1385	2.80	12.32
CFR160/STD/750-3	750	0.25	1340	0.70	2.24
CFR160/STD/850-3	850	0.25	1340	0.70	2.24
CFR160/STD/950-3	950	0.37	1370	1.18	3.89
CFR160/STD/1050-3	1050	0.37	1370	1.18	3.89
CFR160/STD/1150-3	1150	0.55	1400	1.60	5.76
CFR160/STD/1250-3	1250	0.75	1410	2.20	9.68
CFR160/STD/1350-3	1350	1.10	1385	2.80	12.32
CFR160/HP/1000-3	1000	0.25	1340	0.70	2.24
CFR160/HP/1100-3	1100	0.37	1370	1.18	3.89
CFR160/HP/1200-3	1200	0.37	1370	1.18	3.89
CFR160/HP/1300-3	1300	0.55	1400	1.60	5.76
CFR160/HP/1400-3	1400	0.55	1400	1.60	5.76
CFR160/HP/1500-3	1500	0.75	1410	2.20	9.68
CFR160/HP/1600-3	1600	1.10	1385	2.80	12.32
CFR180/STD/900-3	900	0.37	1370	1.18	3.89
CFR180/STD/1000-3	1000	0.55	1400	1.60	5.76
CFR180/STD/1100-3	1100	0.75	1410	2.20	9.68
CFR180/STD/1200-3	1200	1.10	1385	2.80	12.32
CFR180/STD/1300-3	1300	1.50	1400	3.60	20.52
CFR180/STD/1400-3	1400	1.50	1400	3.60	20.52
CFR180/STD/1500-3	1500	2.20	1400	5.30	25.44

3 Phase Motor Details					
Model	Fan RPM	Motor size (kW)	Motor RPM	FLC**	SC*
CFR180/HP/950-3	950	0.37	1370	1.18	3.89
CFR180/HP/1050-3	1050	0.55	1400	1.60	5.76
CFR180/HP/1150-3	1150	0.55	1400	1.60	5.76
CFR180/HP/1250-3	1250	0.75	1410	2.20	9.68
CFR180/HP/1350-3	1350	1.10	1385	2.80	12.32
CFR180/HP/1450-3	1450	1.50	1400	3.60	20.52
CFR180/HP/1550-3	1550	1.50	1400	3.60	20.52
CFR180/HP/1650-3	1650	2.20	1400	5.30	25.44
CFR200/STD/600-3	600	0.25	1340	0.70	2.24
CFR200/STD/700-3	700	0.37	1370	1.18	3.89
CFR200/STD/800-3	800	0.55	1400	1.60	5.76
CFR200/STD/900-3	900	0.75	1410	2.20	9.68
CFR200/HP/1000-3	1000	1.10	1385	2.80	12.32
CFR200/STD/1100-3	1100	1.50	1400	3.60	20.52
CFR200/STD/1200-3	1200	2.20	1400	5.30	25.44
CFR200/HP/900-3	900	0.55	1400	1.60	5.76
CFR200/HP/1000-3	1000	0.75	1410	2.20	9.68
CFR200/HP/1100-3	1100	1.10	1385	2.80	12.32
CFR200/HP/1200-3	1200	1.50	1400	3.60	20.52
CFR200/HP/1300-3	1300	1.50	1400	3.60	20.52
CFR200/HP/1400-3	1400	2.20	1400	5.30	25.44
CFR200/HP/1500-3	1500	2.20	1400	5.30	25.44
CFR200/HP/1600-3	1600	3.00	1425	6.80	31.28
CFR240/STD/425-3	425	0.18	1330	0.60	1.38
CFR240/STD/525-3	525	0.37	1370	1.18	3.89
CFR240/STD/625-3	625	0.55	1400	1.60	5.76
CFR240/STD/725-3	725	1.10	1385	2.80	12.32
CFR240/STD/825-3	825	1.50	1400	3.60	20.52
CFR240/STD/925-3	925	2.20	1400	5.30	25.44
CFR240/HP/730-3	730	0.55	1400	1.60	5.76
CFR240/HP/830-3	830	1.10	1385	2.80	12.32
CFR240/HP/930-3	930	1.10	1385	2.80	12.32
CFR240/HP/1030-3	1030	1.50	1400	3.60	20.52
CFR240/HP/1130-3	1130	2.20	1400	5.30	25.44
CFR240/HP/1230-3	1230	3.00	1425	6.80	31.28
CFR300/STD/500-3	500	1.10	1385	2.80	12.32
CFR300/STD/600-3	600	1.50	1400	3.60	20.52
CFR300/STD/700-3	700	2.20	1400	5.30	25.44
CFR300/STD/800-3	800	3.00	1425	6.80	31.28
CFR300/STD/900-3	900	5.50	1430	11.40	74.10
CFR300/HP/550-3	550	0.75	1410	2.20	9.68
CFR300/HP/650-3	650	1.10	1385	2.80	12.32
CFR300/HP/750-3	750	2.20	1400	5.30	25.44
CFR300/HP/850-3	850	3.00	1425	6.80	31.28
CFR300/HP/950-3	950	4.00	1400	9.20	55.20
CFR300/HP/1050-3	1050	5.50	1430	11.40	74.10
CFR360/HP/550-3	550	2.20	1400	5.30	25.44
CFR360/HP/600-3	600	3.00	1425	6.80	31.28
CFR360/HP/650-3	650	4.00	1400	9.20	55.20
CFR360/HP/700-3	700	4.00	1400	9.20	55.20
CFR360/HP/750-3	750	5.50	1430	11.40	74.10
CFR360/HP/800-3	800	5.50	1430	11.40	74.10
CFR360/HP/850-3	850	7.50	1445	14.80	96.20

* SC - Nominal starting current (A)

** FLC - Full load starting current (A)



Centrifume - CFR Units

Installation, Operation and Maintenance Manual

5 Wiring continued

Fig. 9 Standard electrical details • Single Phase 230V 50Hz

1 Phase Motor Details					
Model	Fan RPM	Motor size (kW)	Motor RPM	FLC**	SC*
CFR100/STD/1000-1	1000	0.18	1290	2.00	3.60
CFR100/STD/1100-1	1100	0.18	1290	2.00	3.60
CFR100/STD/1200-1	1200	0.18	1290	2.00	3.60
CFR100/STD/1300-1	1300	0.18	1290	2.00	3.60
CFR100/STD/1400-1	1400	0.18	1290	2.00	3.60
CFR100/STD/1500-1	1500	0.25	1340	2.30	5.06
CFR100/STD/1600-1	1600	0.25	1340	2.30	5.06
CFR100/STD/1700-1	1700	0.37	1370	8.10	3.00
CFR100/HP/1300-1	1300	0.18	1290	2.00	3.60
CFR100/HP/1500-1	1500	0.18	1290	2.00	3.60
CFR100/HP/1700-1	1700	0.18	1290	2.00	3.60
CFR100/HP/1900-1	1900	0.25	1340	2.30	5.06
CFR100/HP/2100-1	2100	0.37	1370	8.10	3.00
CFR100/HP/2300-1	2300	0.37	1370	8.10	3.00
CFR100/HP/2500-1	2500	0.55	1390	4.00	12.80
CFR120/STD/700-1	700	0.18	1290	2.00	3.60
CFR120/STD/800-1	800	0.18	1290	2.00	3.60
CFR120/STD/900-1	900	0.18	1290	2.00	3.60
CFR120/STD/1000-1	1000	0.18	1290	2.00	3.60
CFR120/STD/1100-1	1100	0.18	1290	2.00	3.60
CFR120/STD/1200-1	1200	0.18	1290	2.00	3.60
CFR120/STD/1300-1	1300	0.25	1340	2.30	5.06
CFR120/STD/1400-1	1400	0.25	1340	2.30	5.06
CFR120/STD/1500-1	1500	0.37	1370	3.00	8.10
CFR120/STD/1600-1	1600	0.37	1370	3.00	8.10
CFR120/STD/1700-1	1700	0.55	1390	4.00	12.80
CFR140/STD/700-1	700	0.25	1340	2.30	5.06
CFR140/STD/800-1	800	0.25	1340	2.30	5.06
CFR140/STD/900-1	900	0.25	1340	2.30	5.06
CFR140/STD/1000-1	1000	0.25	1340	2.30	5.06
CFR140/STD/1100-1	1100	0.37	1370	3.00	8.10
CFR140/STD/1200-1	1200	0.37	1370	3.00	8.10
CFR140/STD/1300-1	1300	0.55	1390	4.00	12.80
CFR140/STD/1400-1	1400	0.55	1390	4.00	12.80
CFR140/STD/1500-1	1500	0.55	1390	4.00	12.80
CFR140/STD/1600-1	1600	0.75	1445	4.90	26.64
CFR160/STD/750-1	750	0.25	1340	2.30	5.06
CFR160/STD/850-1	850	0.25	1340	2.30	5.06
CFR160/STD/950-1	950	0.37	1370	3.00	8.10
CFR160/STD/1050-1	1050	0.37	1370	3.00	8.10
CFR160/STD/1150-1	1150	0.55	1390	4.00	12.80
CFR160/STD/1250-1	1250	0.75	1445	4.90	26.64
CFR160/HP/1000-1	1000	0.25	1340	2.30	5.06
CFR160/HP/1100-1	1100	0.37	1370	3.00	8.10
CFR160/HP/1200-1	1200	0.37	1370	3.00	8.10
CFR160/HP/1300-1	1300	0.55	1390	4.00	12.80
CFR160/HP/1400-1	1400	0.55	1390	4.00	12.80
CFR160/HP/1500-1	1500	0.75	1445	4.90	26.64

1 Phase Motor Details					
Model	Fan RPM	Motor size (kW)	Motor RPM	FLC**	SC*
CFR180/STD/800-1	800	0.37	1370	3.00	8.10
CFR180/STD/900-1	900	0.37	1370	3.00	8.10
CFR180/STD/1000-1	1000	0.55	1390	4.00	12.80
CFR180/STD/1100-1	1100	0.75	1445	4.90	26.64
CFR180/STD/1200-1	1200	1.10	1415	7.40	26.64
CFR180/STD/1300-1	1300	1.50	1430	9.00	42.30
CFR180/STD/1400-1	1400	1.50	1430	9.00	42.30
CFR180/STD/1500-1	1500	2.20	1450	12.50	57.50
CFR180/HP/950-1	950	0.37	1370	3.00	8.10
CFR180/HP/1050-1	1050	0.55	1390	4.00	12.80
CFR180/HP/1150-1	1150	0.55	1390	4.00	12.80
CFR180/HP/1250-1	1250	0.75	1445	4.90	26.64
CFR180/HP/1350-1	1350	1.10	1415	7.40	26.64
CFR180/HP/1450-1	1450	1.50	1430	9.00	42.30
CFR180/HP/1550-1	1550	1.50	1430	9.00	42.30
CFR180/HP/1650-1	1650	2.20	1450	12.50	57.50
CFR200/STD/600-1	600	0.25	1340	2.30	5.06
CFR200/STD/700-1	700	0.37	1370	3.00	8.10
CFR200/STD/800-1	800	0.55	1390	4.00	12.80
CFR200/STD/900-1	900	0.75	1445	4.90	26.64
CFR200/STD/1000-1	1000	1.10	1415	7.40	26.64
CFR200/STD/1100-1	1100	1.50	1430	9.00	42.30
CFR200/STD/1200-1	1200	2.20	1450	12.50	57.50
CFR200/HP/900-1	900	0.55	1390	4.00	12.80
CFR200/HP/1000-1	1000	0.75	1445	4.90	26.64
CFR200/HP/1100-1	1100	1.10	1415	7.40	26.64
CFR200/HP/1200-1	1200	1.50	1430	9.00	42.30
CFR200/HP/1300-1	1300	1.50	1430	9.00	42.30
CFR200/HP/1400-1	1400	2.20	1450	12.50	57.50
CFR200/HP/1500-1	1500	2.20	1450	12.50	57.50
CFR240/STD/425-1	425	0.18	1290	2.00	3.60
CFR240/STD/525-1	525	0.37	1370	3.00	8.10
CFR240/STD/625-1	625	0.55	1390	4.00	12.80
CFR240/STD/725-1	725	1.10	1415	7.40	26.64
CFR240/STD/825-1	825	1.50	1430	9.00	42.30
CFR240/STD/925-1	925	2.20	1450	12.50	57.50
CFR240/HP/730-1	730	0.55	1390	4.00	12.80
CFR240/HP/830-1	830	1.10	1415	7.40	26.64
CFR240/HP/930-1	930	1.10	1415	7.40	26.64
CFR240/HP/1030-1	1030	1.50	1430	9.00	42.30
CFR240/HP/1130-1	1130	2.20	1450	12.50	57.50
CFR300/STD/500-1	500	1.10	1415	7.40	26.64
CFR300/STD/600-1	600	1.50	1430	9.00	42.30
CFR300/STD/700-1	700	2.20	1450	12.50	57.50
CFR300/HP/550-1	550	0.75	1445	4.90	26.64
CFR300/HP/650-1	650	1.10	1415	7.40	26.64
CFR300/HP/750-1	750	2.20	1450	12.50	57.50
CFR360/HP/550-1	550	2.20	1450	12.50	57.50

* SC - Nominal starting current (A)
 ** FLC - Full load starting current (A)



Centrifume - CFR Units

Installation, Operation and Maintenance Manual

5 Wiring continued

Standard motor wiring arrangement

Fig.10 Standard wiring arrangement to local isolator

Note: 2 speed motors are dual wound as standard

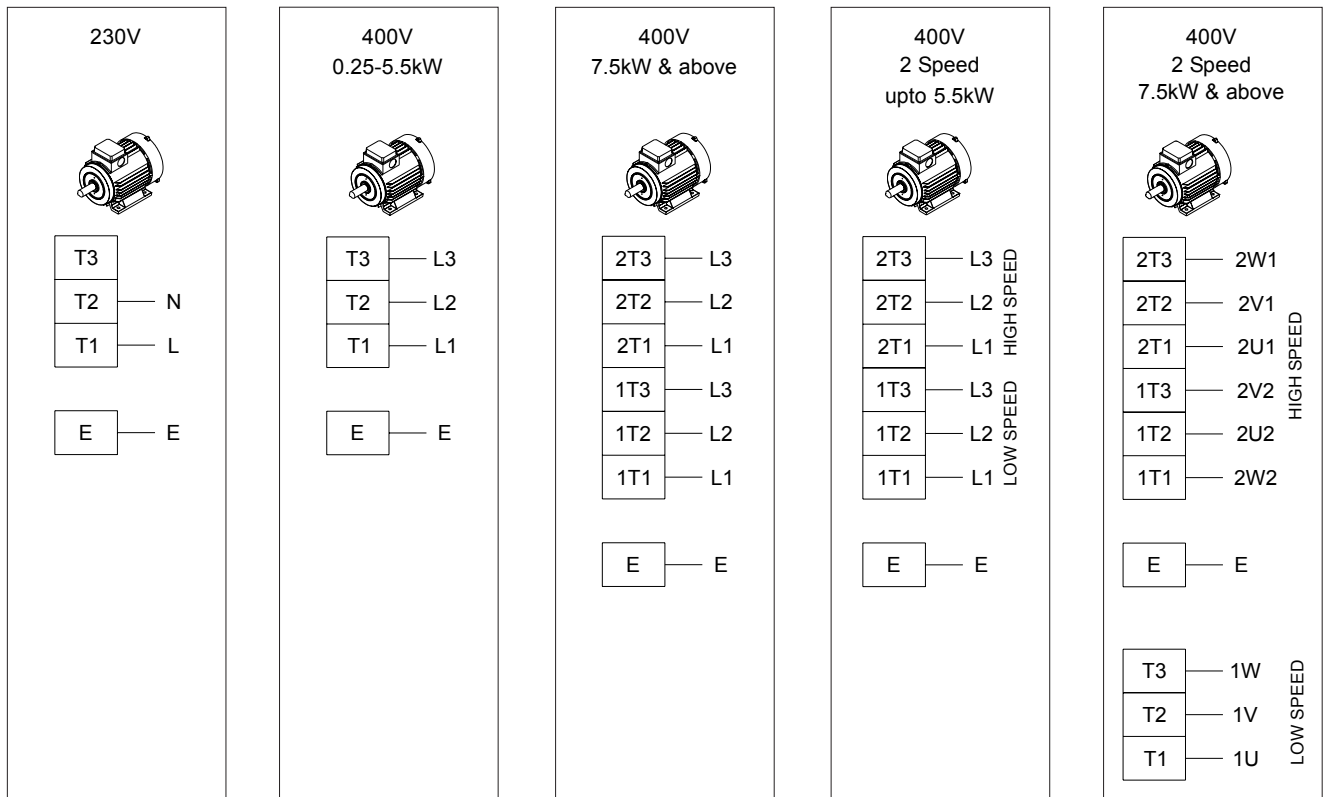



Centrifume - CFR Units

Installation, Operation and Maintenance Manual

6 Maintenance

IMPORTANT !

Before attempting to carry out any maintenance work, investigative or repair work on our units, the unit **MUST BE COMPLETELY ISOLATED** from its electrical supply. Ensure a minimum of two minutes after electrical disconnection before removing access panels. This will allow any moving parts to come to a rest

The fan and motor bearings are sealed for life and supplied fully greased and lubricated. The bearings have a life of 10,000 hours, after which they need to be changed. Please contact VES Customer Services for replacement parts.
Tel: **08702 404340**

IMPORTANT !

Before attempting to carry out any work on our units, all accompanying documentation including warning labels on the unit must be referenced.

WARNING !

When used in conjunction with an inverter for speed control, a minimum of 5 minutes should be given to allow for the capacitors to discharge before starting work after disconnection from the power source

Recommended checks

This range of units will require regular maintenance if located in greasy air systems. In order to keep the unit in good order the following maintenance routine is recommended:

Three Monthly Check

The belt drive should be thoroughly checked. Belts are subject to fatigue and will stretch over a period of time. Within normal operating conditions, belts tend to stretch in the first few days of running. Inspection of belts at this early stage is advised. After this initial period, regular 3 monthly checks should be made. If belts are found to be loose or worn, retighten by moving the position of the motor plate, slacken bolts and slide the motor plate down, retighten the bolts. Refer to *fig.5* for the recommended tension. Replace belts if necessary.

Excessive wear on both sides of the belts usually indicates a misalignment of the pulleys and this should be rectified at once see *fig.4*. New and used belts should not be run together in the same set. Belts of different types and brands should not be mixed. Always fit ALL NEW matched belts in the same set.

A check for excessive noise or vibration should be carried out. This will help to identify fan or motor defects before they develop. The cause of excessive noise or vibration could be due to: loose connections, mis-aligned fan belts, unbalanced fans or worn bearings.

WARNING !

Debris from kitchen environments can sometimes be found stuck to the fan impeller. This debris will cause the fan to become unbalanced, reduce its airflow, become noisy and eventually fail. The impeller should be regularly checked if this is a possibility.

Six Monthly Check

Check for contaminants in the system, especially around the drain pan (if fitted), impeller and inlet eye. Remove any residue if necessary and empty the drain trough if fitted.

Annual Check

It is recommended that the unit's casework and fixings are checked for signs of deterioration, particularly where adverse environmental conditions prevail. Repair or replace components if necessary.

IMPORTANT !

It is critical that after any maintenance work has been conducted that all components removed/replaced be refitted correctly by a competent engineer.

WEEE Directive



At the end of their useful life the packaging and product should be disposed of via a suitable recycling centre. Do not dispose of with normal household waste. Do not burn.

When enquiring after or ordering spares contact VES Spares Department, quoting the sales order (SO) number and unit type as found on the unit nameplate.

Telephone 08702 40 43 40
Fax 08702 40 45 50



PLEASE ENSURE THAT THIS DOCUMENT IS PASSED ON TO THE END USER.

We reserve the right to alter the specification without notice

©VES Andover Ltd. 2006

No part of this publication may be photocopied or otherwise reproduced without the prior permission in writing of VES Andover Ltd.



Centrifume - CFR Units

Installation, Operation and Maintenance Manual

7 Warranty

Extended Warranties

All VES Andover Products come with a one year guarantee from date of dispatch, which covers parts and labour. You can now extend this with the following options:

Option 1. **FREE extended Warranty**

We can offer you a maintenance agreement that keeps this equipment in tip-top condition. If you take out this agreement, we will extend the warranty **free of charge for up to 5 years**, providing the regular maintenance agreement remains in place.

Option 2. **12-24 Month Extended Warranty**

12-24 months from the date of dispatch. This can be covered at a cost of just 3% of order value. (minimum charge £50.00).

Option 3. **12-36 Month Extended Warranty**

12-36 months from date of dispatch. For this cover, the charge is 6% of order value (Minimum charge £80)

Please State which option you require when you place your order. A transferable certificate will then be issued to you. *Please note, this offer excludes condensing units. We would be happy to quote you for these separately.*

Register for separate spares reminders and get a 10% discount

Register for this free service and we will automatically send you a regular reminder detailing the consumable spares for this unit, together with their current list prices.

You will then be entitled to a 10% discount off any spares.

To arrange any of these options.

or **Phone: 023 8046 1150**
Email: spares@ves.co.uk

Stating the sales order and reference number from the unit.



Centrifume - CFR Units

Installation, Operation and Maintenance Manual



Declaration of Conformity

Date: 26th June 2006
Product: Centrifume
Type: CFR units
Manufacturer: VES Andover Limited

The product above is produced in accordance with EC Council Directives:

98/37/EC (Machinery Directive)
89/336/EEC and amendment 92/31/EEC (Electromagnetic Compatibility Directive)
73/223/EEC and amendment 93/68/EEC (Low Voltage Directive)

The European Harmonised Standards applied are:

BS EN ISO 12100, EN 294, EN61000, EN 60204-1

The National Standards applied in particular are :

BS 848 Part 1

Basis of Self attestation:

Quality Assurance to ISO 9001-2000, BSI Reg. Firm Cert. No. Q5375

Signature of Manufacturer:

Position of Signatory:

Technical Director