

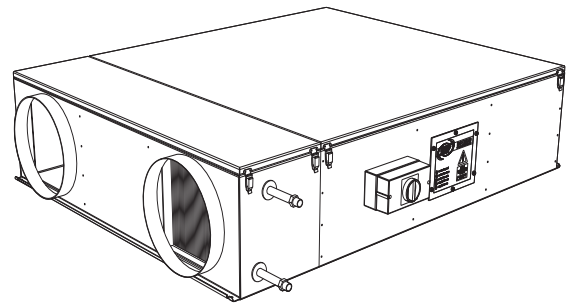

# ecovent **NRG** Air Handling Units

## Installation, Operation and Maintenance Manual

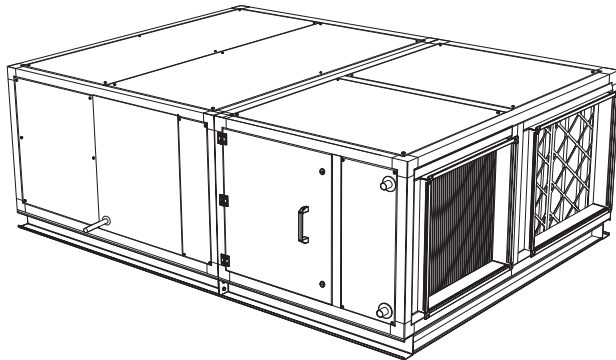

**Important**  **This manual must be read in full before Installation, Operation and Maintenance of the units supplied**

Please ensure that this document is passed to the end user. This manual forms an integral part of the product and should be kept for the working life of the product. Additional copies of this and supporting documents are available by contacting VES or by visiting [www.ves.co.uk](http://www.ves.co.uk) and following the 'Download O & M's' link.

The following symbols used within this document refer to potential dangers or advice for safe operation



Indicates hazards associated with electric current and high voltages



Indicates hazards that require safety advice for personnel and/or potential unit/property damage



Indicates important information

	Page
<b>1</b> Introduction	1
<b>2</b> Nomenclature	2
<b>3</b> Receipt of Goods & Handling	3
<b>4</b> Installation	3
<b>5</b> Standard Wiring & Fan Installation	10
<b>6</b> Maintenance	14
<b>7</b> Declaration of Conformity	15
<b>8</b> Extended Warranty	16

**Introduction 1** The **ecovent NRG** series are a range of air handling units, direct and inverter driven, with duties up to 2.5m<sup>3</sup>/s. Suitable for either plantroom, ceiling void or external locations, each unit will have been supplied with either no pre-wiring, pre-wired to an external isolator or with fitted control panel as specified at the time of order.  
The standard operating temperature of these units is -20 to +35°C.

For further technical details regarding dimensions and weights, contact VES on **08448 15 60 60**, quoting the sales order (SO) number and the unit type as found on the unit nameplate or visit [www.ves.co.uk](http://www.ves.co.uk).



# ecovent NRG Air Handling Units

## Installation, Operation and Maintenance Manual

### Nomenclature 2

Part Number Coding

Point Description	Point Variants	Details (as appropriate)
1 Product	<b>NRG</b>	ecovent NRG Air Handling Units
2 Unit Size	<b>0...9</b>	Sequential see unit outline for details
3 Fan Type	<b>5</b> <b>6</b>	Backward curve centrifugal fan Backward curve plug fan
4 Fan Size	<b>3...9</b>	Sequential
5 Phase	<b>-1</b> <b>-3</b>	230V 50Hz Single Phase 400V 50Hz Three Phase
6 Wiring	<b>Null</b> <b>S</b> <b>D</b>	Not appropriate Star Delta
7 Unit Configuration	<b>/P</b> <b>/W</b> <b>/SP</b> <b>/SW</b>	Plantroom (flat) Weatherproof (flat) Plantroom (stacked) Weatherproof (stacked)
8 Main Heating	<b>Null</b> <b>-E</b> <b>-W</b>	No Heating Electric Heater Battery LPHW Coil
9 Infill	<b>Null</b> <b>/DS</b> <b>/PB</b> <b>/EE</b>	Single Skinned 25mm double skinned, mineral wool infill 25mm double skinned, plasterboard infill 50mm double skinned, mineral wool infill
10 Handing (denotes position of supply fan position LIDAF)	<b>/RT</b> <b>/RB</b> <b>/LT</b> <b>/LB</b> <b>/R</b> <b>/L</b>	Right/Top Access Right/Bottom Access Left/Top Access Left/Bottom Access Right Left
11 Main Filter	<b>Null</b> <b>/F</b> <b>/R5...R8</b>	No filter EU4 Pleated Filter High efficiency pleated filter
12 Control Panel Section	<b>Null</b> <b>/I</b> <b>/CP</b> <b>/FS</b> <b>/CS</b>	No fitted controls Pre-wired isolator/s Fitted control panel Fitted speed controller/s Fitted control panel/speed controller/s
13 Twin Fan	<b>Null</b> <b>/TF</b>	No twin fan Twin Fan Extract configuration
14 Colour	<b>Null</b> <b>/00A05</b>	Galvanised finish Powdercoated finish, BS00A05 etc...
15 Powder Coat Type	<b>Null</b> <b>/IT</b> <b>/BT</b>	As colour Internal powdercoated only Internal/External powdercoated
16 Special	<b>/S</b>	Special (non-standard) Unit

#### Typical Example

NRG557-3D/SP-W/DS/L/F/CP/S

NRG 5 5 7 -3 D /SP -W /DS /L /F /CP /S

① ② ③ ④ ⑤ ⑥ ⑦ ⑧ ⑨ ⑩ ⑪ ⑫ ⑬ ⑭ ⑮ ⑯



# ecovent NRG Air Handling Units

## Installation, Operation and Maintenance Manual

### Receipt of Goods & Handling 3

Immediately upon receipt of goods, check for possible damage in transit paying particular attention to fan impellers, coil connections and unit casing. Prior to installation please check to ensure alignment and smooth rotation of the impeller after transit. Also check to ensure that any ancillary items are included. These will normally be supplied fitted or, in the case of small items, taped to the unit.

In the event of any damage having occurred or if any item is found to be missing, it is essential to inform VES Andover Ltd. within **7 days** of delivery quoting sales order number and the unit type, as found on the unit nameplate.

After this period, VES would be unable to accept any claim for damaged or missing goods.

### Installation 4

The entire system must be considered for safety purposes and it is the responsibility of the installer to ensure that all of the equipment is installed in compliance with the manufacturer's recommendations, with due regard to the current HEALTH AND SAFETY AT WORK ACT and conforms to all relevant statutory regulations.

Where a unit is installed so that a failure of components could result in injury to personnel, precautions should be taken to prevent such an injury. If the unit is installed where there is a reasonable possibility of persons or objects coming into contact with the impeller whilst operational, a guard should be fitted or steps taken to prevent this.

It is the installer's responsibility to ensure that access panels are not obstructed in any way and safe working access for maintenance must be provided in accordance with Health and Safety and Building Regulations. For confirmation of required access please see the appropriate unit outline drawing; note that some access doors are hinged.

For optimum unit performance, careful consideration must be paid to the location of the unit in relation to the ductwork and associated items; placing the unit directly adjacent to a bend in ductwork will impede airflow and reduce performance.

Consideration must also be given by the installer for adequate illumination of the unit location in order for safe maintenance.

**Caution**  Handles, lids, housings and coil connections must NOT be used as lifting points

When moving the unit, handle with care and in such a manner as to avoid damaging the external finish as this may reduce the ability to resist corrosion.

Units are to be rigged and lifted using spreaders, taking into account the weight of the unit, and lifting gear should be arranged so as not to bear on the casework see right.

Lifting detail  
Fig. 1

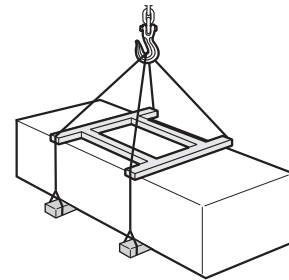

**Important**  Larger NRG units are sectional. It is important to ensure that all sections are joined together securely prior to positioning and installation.

Units that are supplied in one section as standard will be factory assembled with the appropriate fixings. Units over 2.5 metres in length and units with fitted silencers may be supplied in sections, and some site assembly will be required. Units supplied in sectional form should be assembled using self-adhesive rubber tape at the joints prior to assembly so as to prevent air leakage; replace with similar if damaged.

**Caution**  Units should only be supported using the support feet or channel base as provided by VES with the unit. Contact VES before attempting to support the unit using alternative methods. Only experienced fitters should undertake this work. Take necessary safety precautions when working in elevated positions.

**Important**  For associated components (inverters, speed controllers, controls) please refer to the relevant accompanying O&M

# ecovent NRG Air Handling Units

## Installation, Operation and Maintenance Manual

### Installation 4 Continued

#### Size 0/1/2

Size 0/1/2 units are supplied with feet suitable for floor or ceiling-void mounting, either by use of drop-rod mounting, in either top or bottom access orientation, with airflow in the horizontal plane. For alternative mounting please consult your outline drawing as supplied with the unit, or refer to VES Customer Services for further information.

### Important !

When hanging units from drop-rods, ensure that the load is evenly spread and that all feet are used within the support. It is important that the unit is level to ensure all components operate correctly.

Secure drop rods/unit with M10 fixings as shown below ②.

Self-levelling feet are available for floor mounting, with M10 fixings as per drop rods ③. If required the unit can be further secured to the floor via knockout fixings holes on the feet, fixings to be supplied by others ④.

Size 0/1/2 unit mounting

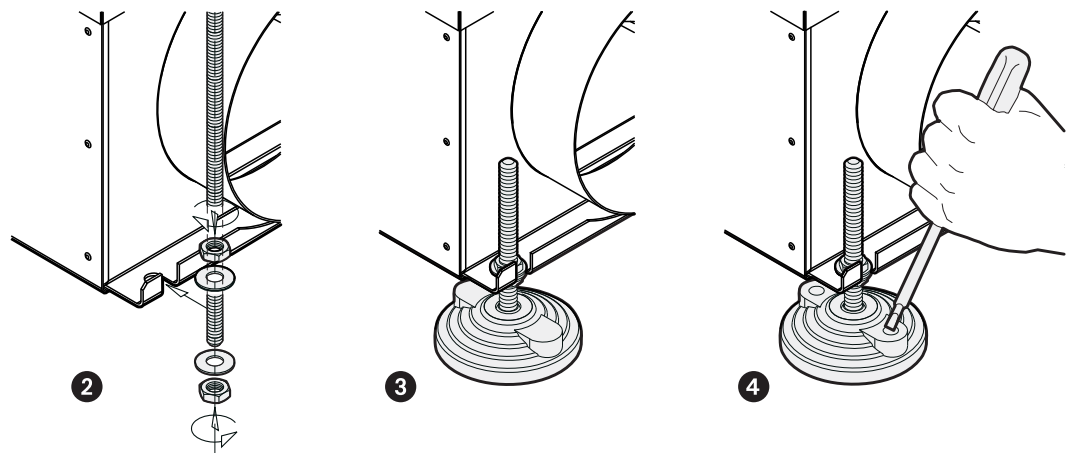

Standard units should be mounted in the horizontal plane, level with lid access to the top or bottom. For alternative mounting please consult your outline drawing as supplied with the unit, or refer to VES Customer Services for further information.

Size 0 unit handing

Size 0 unit handing is determined by the location of the extract airstream, with the drain pan located on the air-off side of the heat exchanger as shown in ⑤, the default setup as shown.

### Important !

Handing reorientation is **ONLY** appropriate when site conditions dictate the use of the condensate drain. If the drain is redundant the unit can be fitted without alteration, with fans to the left or right and access top or bottom.

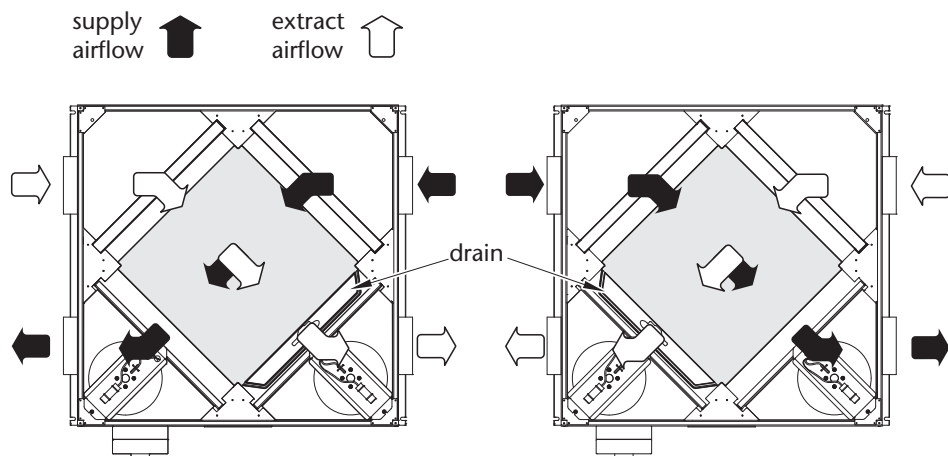

Size 0 unit reorientation

⑤ Default unit setup with fans to the left hand side looking in direction of supply airflow

⑥ Reorientated unit setup with fans to the right hand side looking in direction of supply airflow

# ecovent **NRG** Air Handling Units

## Installation, Operation and Maintenance Manual

### Installation **4** Size 0

#### Continued

The unit comes fitted with an ABS drainpan as standard, for use with an optional peristaltic pump. See later in this section for instruction on fitting the pump and sensor. Should the unit handling need alteration follow the following instructions in figure **7**

### Important



This drain is **NOT** suitable for trapping by traditional trapping methods

Top access unit  
drainpan  
reorientation  
Fig. **7**

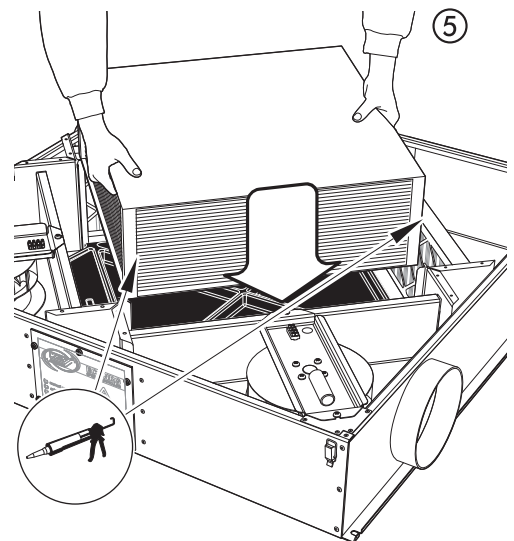
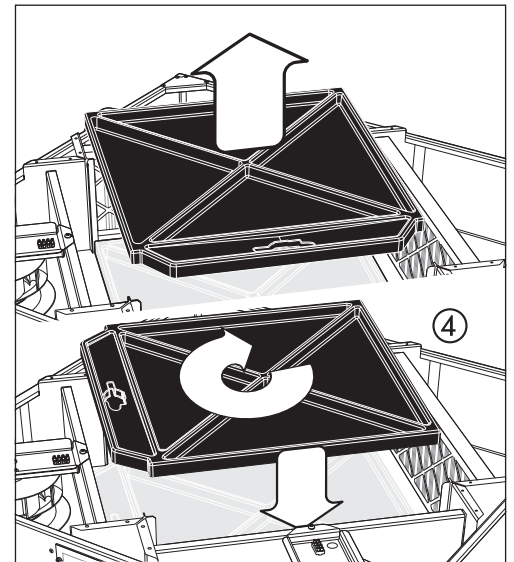
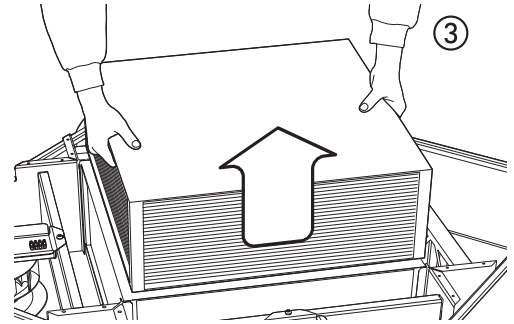
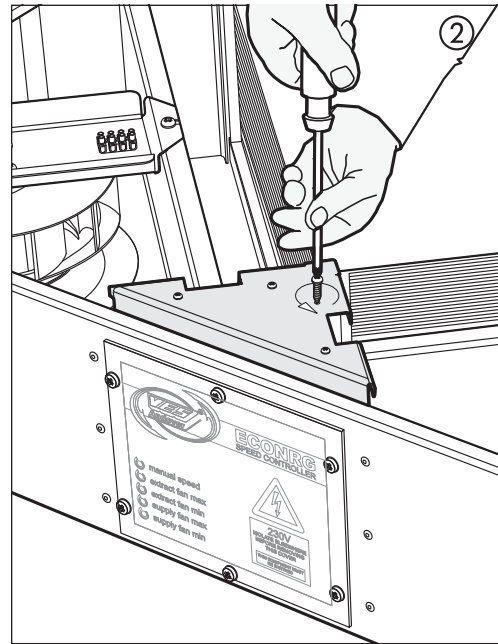

- ① Remove the lid.
- ② Using a cross-head screw driver, remove the four support covers as shown, retaining the screws. Take especial care when working around the speed controller section.
- ③ Remove the heat exchanger, carefully lifting straight up and out, taking care not to damage the heat exchanger fins or seal whilst doing so.
- ④ Withdraw the drainpan, turn anticlockwise 90° (so that the drain part of the tray is adjacent to the other fan) and replace. Note: fitting the pump sensor can be easier when the drain pan is outside the unit.
- ⑤ Replace the heat exchanger and silicon into place along all supporting upright angles as shown.
- ⑥ Replace and secure the four support covers, taking care to ensure the heat exchanger assembly is safely held in position.
- ⑦ Replace the lid, ensuring all fasteners are closed.



# ecovent NRG Air Handling Units

## Installation, Operation and Maintenance Manual

### Installation 4 Continued

#### Size 0

#### Bottom access unit drainpan reorientation

Fig. 8

- ① Remove the lid
- ② Using a cross-head screw driver, remove the four support covers as shown, retaining the screws. Take especial care when working around the speed controller.
- ③ Remove the heat exchanger, carefully lifting straight up and out, taking care not to damage the heat exchanger fins or seal whilst doing so.
- ④ Remove/retain the drain pan
- ⑤ Replace the heat exchanger and silicon into place along upright angles
- ⑥ Turn the drain pan over so that the drain sump now faces the heat exchanger (upside-down), and replace in the unit making sure that the drain is adjacent to the extract-off side of the heat exchanger.  
Note: fit the pump sensor prior to returning the drain pan to the unit. Sensor pipework will also need to be routed before replacing the drain pan (see next page for details).
- ⑦ Replace and secure the four support covers, taking care to ensure the heat exchanger assembly is safely held in position
- ⑧ Replace the lid, ensuring all fasteners are closed

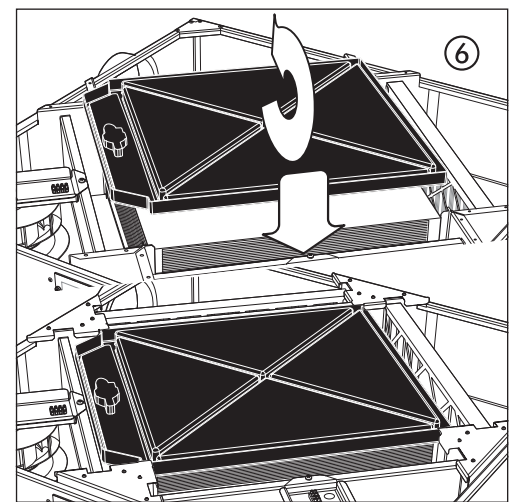
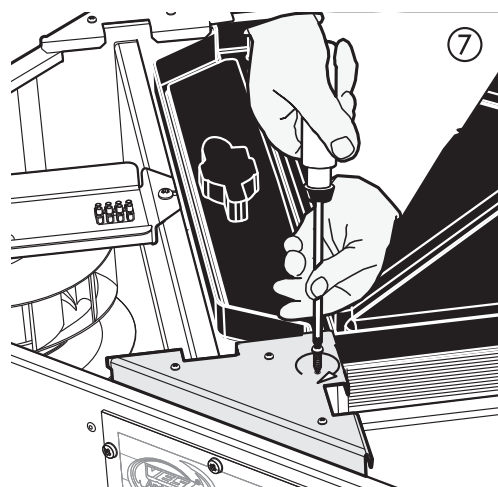
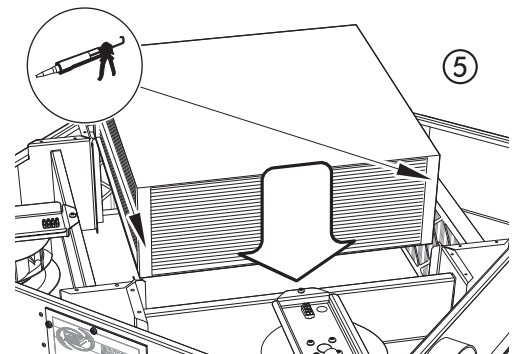
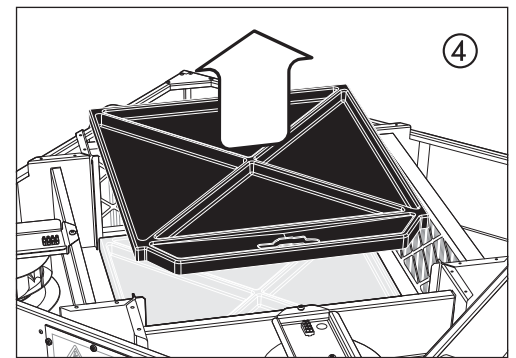
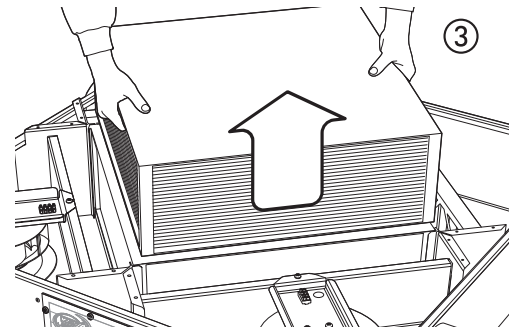

#### Important



When reorientating the unit the speedcontroller label may be now be incorrect/upside-down. Whereas this will not effect the operation you may wish to reorientate this also. Please see the accompanying speed controller documentation for re-wiring details.

#### Warning



The electrical supply **must be fully isolated** before attempting to affect any work on this unit

# ecovent NRG Air Handling Units

## Installation, Operation and Maintenance Manual

### Installation Size 0/1/2 Drain pump & sensor

#### 4 Continued

A drain pan has been provided for use in particular conditions when condensation may form within the heat exchanger in the unit. The drain pan has been specifically designed for use with a peristaltic pump assembly, also available from VES, and has been designed to allow the pump sensor to be seated within a small sump to allow condensation collection as required.

### Important



For full fitting/installation instructions see the documentation accompanying the pump assembly.

#### Pump installation Fig. 9

- ① Fix the pump mounting plate to the unit. Ensure placement is the correct way up, taking special notice on bottom access units
- ② Slide the pump down onto the bracket as shown.
- ③ Fit the pump sensor in the drain pan sump as shown. Secure the sensor into place using silicon or similar, taking care not to block the any of the sensor connections. Give full time for adhesive to dry before use.
- ④ It is important that the sensor/drain pan assembly is level. Failure to do so may cause the pump sensor to become inoperative and so disable the pump.
- ⑤ Make the required connections as per the pump O&M, ensuring that all associated pipe work and wiring inside the unit is carefully stowed so as not to foul on any moving components.
- ⑥ Knock-outs have been provided in the unit casework to allow for best routing. Gland/grommet as required.
- ⑦ Connect the drain to an appropriate waste system. Follow the post-installation instructions as supplied with the pump.

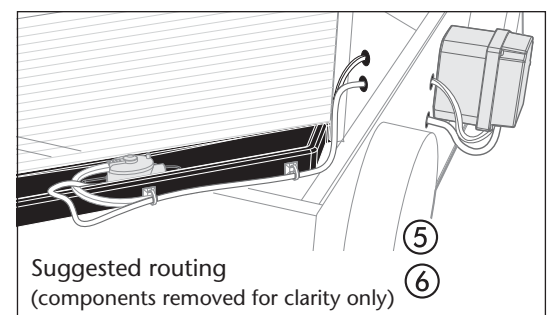
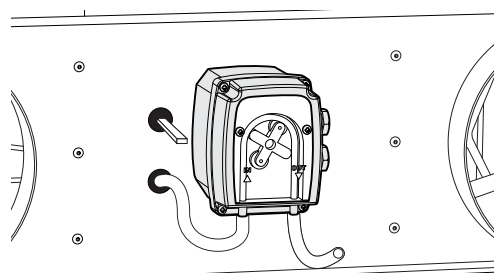
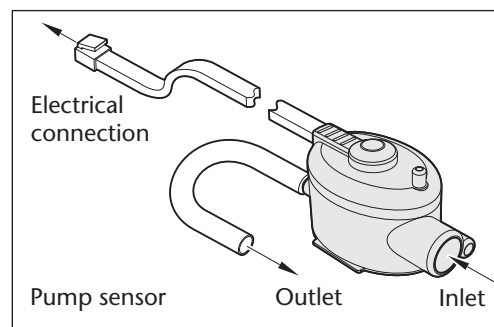
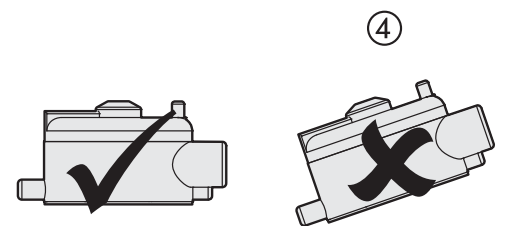
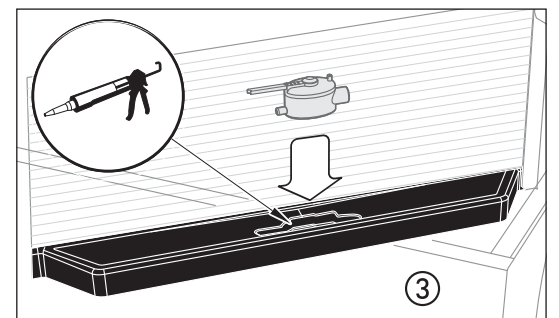
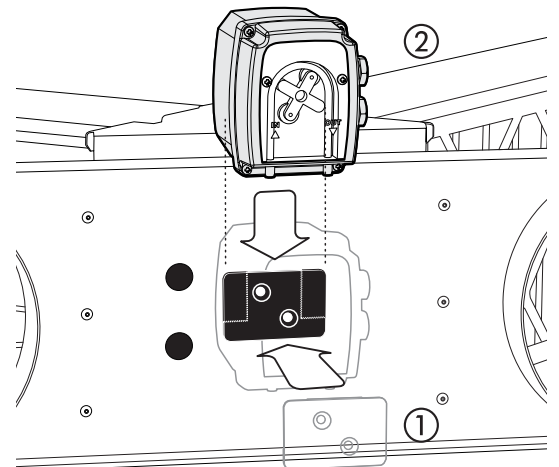



# ecovent **NRG** Air Handling Units

## Installation, Operation and Maintenance Manual

### Installation 4 Electric Heater Batteries

#### 4 Continued

On NRG -E units, an electric heater battery (EHB) coil will be installed. Supply to the heater should be 1ph or 3ph with separate neutrals; confirmation of this can be found on the unit nameplate. Cables should be of silicone rubber, fibreglass or of a similar high temperature insulated type and be installed to current **I.E.E. Regulations**, ensuring a sufficient earth connection to the terminal provided. Care should be taken not to overstrain the terminal pillars as this may permanently damage the elements.

### Important



The heater is fitted with a manual-reset high temperature cutout with normally closed (NC) terminals and is set to break if the duct temperature rises above 130°C. On unit sizes 3 and above there is an additional 70°C auto-reset cutout and airflow pressure switch situated on the fan plate. It is important that both cutouts are connected in series with the main contactor coil circuit if the heater is to be isolated in the event of overheating.

The electrical supply must be isolated before attempting to reset the manual cut-out. For further information regarding electric heaters please see **VES Ref. ID431**.

If a speed controller is fitted to the system, it must not stop the fan independently of the control system, or allow airflow to fall below the stated volume on the electric heater battery. Suitable speed controllers without on/off switches are available from VES Andover.

### Condensate Trapping

Where a traditional drain pan is fitted, please refer to trapping detail manual **VES Ref. ID665**. Consideration should be given to the height required for the trap to function correctly and that the unit may need additional base support in order to accommodate this correctly.

### Coils

Coils should be piped according to any relevant local codes of practice. Where threaded connections are supplied, the only approved method of jointing method is by use of Boss white and hemp. The thread fitted to the coil is to be supported at all times whilst making joints. All external piping is to be supported independently from the coil. Fluid filters are recommended.

### Caution



It is important that water and steam coils are protected against damage from extreme weather conditions during the winter season. If the water is allowed to freeze in the coil system, damage may occur potentially bursting pipes and resulting in emergency problems. Fitting a frost thermostat at the unit inlet and ensuring that boilers run continuously in low ambient temperatures can prevent this.

### Caution



Heating coils do not cool immediately when the hot water supply is cut off. The residual heat must be dissipated to avoid damage. The continuous running of the fan after shutdown resolves this, by operation of a run-on timer. The recommended length of run-on is **2 minutes minimum**.

### Hot Water (LPHW) Coils

On NRG -W units, a Low Pressure Hot Water (LPHW) coil will be installed. The coils are normally suitable for LPHW at 82°C flow and 71°C return temperature. LPHW coils are supplied as standard with an air vent and drain plug located on the pipe work immediately adjacent to the coil connections on the AHU. The air vent should be at the highest point, with the drain at the lowest. The coil should be regularly vented so as to avoid potential air locks, resulting in a fall off of duty.

It is recommended that a check be made as to whether any treatment is required to the water supply for prevention of corrosion and scaling of the equipment. Information regarding the necessary action to be taken can be obtained from the relevant Water Supply Authority.

The unit will have been supplied with connections either left or right-hand side looking in direction of airflow. Please see order acknowledgement for confirmation of this handing. Should you need to alter this please consult VES as unit adjustment may invalidate your warranty.





# ecovent NRG Air Handling Units

## Installation, Operation and Maintenance Manual

### Installation 4 Continued

#### Coils

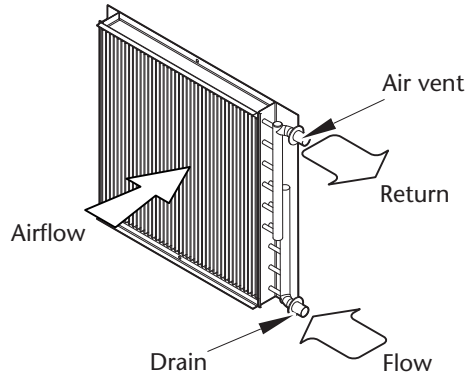

Typical LPHW Coil  
 Fig. 10

#### Steam Coils

Steam coils are suitable for use with saturated steam up to 100psi. The pipe work must be so arranged to provide adequate drain lines with a suitable strainer and steam trap. All steam and drain lines should be lagged. The supply should be taken from the top of the steam main, to avoid the introduction of moisture or air into the coil. The pipe shall be arranged so that it does not interfere with the coil expansion. Where steam coils are fitted it is essential that a time delay is installed in the fan starter control circuit. The fan shall be kept running for at least two minutes after the steam supply to the coils has been shut off, so that residual heat of the coil is dissipated. If the pipe run is unduly long and prone to water logging, it should be properly trapped, just before the coil.

If the steam is from a high pressure steam main, it is essential to have a working pressure relief valve on the low side to ensure that dangerous overheating of the air and excessive pressure cannot occur. Fitting a frost thermostat at the unit inlet and ensuring that boilers run continuously in low ambient temperatures can prevent this.

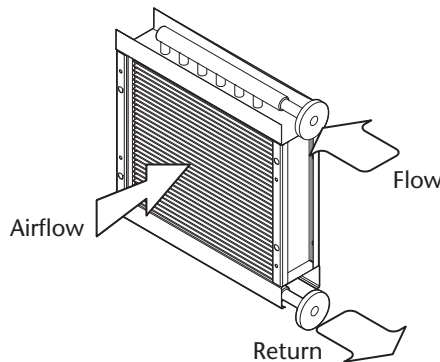

Typical Steam Coil  
 Fig. 11

#### DX Cooling Coils

All cooling coils have fully boxed and insulated cases, with moisture eliminators fitted as standard. The drain pan will require trapping to the drain line, for further information please see VES Ref. ID665. DX and Condenser Coils must be connected to systems in accordance with accepted refrigeration codes of practice and if fitted upstream to steam or water coils, care must be taken to ensure that the air temperature does not drop below 0°C.

For units supplied with condensing units, refer to the appropriate supporting documentation.

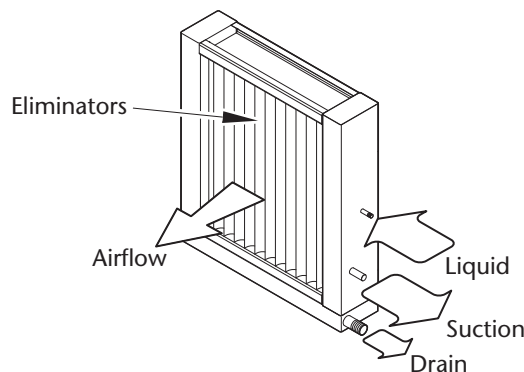

Typical DX Cooling Coil  
 Fig. 12



# ecovent NRG Air Handling Units

## Installation, Operation and Maintenance Manual

### Standard Wiring & Fan Installation 5

**Warning**

The electrical supply **must be fully isolated** before attempting to affect any work on this unit. All electrical connections to any unit must be carried out in accordance with the current edition of the I.E.E Regulations and only competent Electricians should be allowed to affect any electrical work to our units.

**Important**

It is the customer's responsibility to supply earth fault protection through the building installation device and a dedicated, isolated power supply with overload protection, to account for motor start up currents. See the accompanying fan wiring diagram for specific fan details.

**Warning**

Do not connect any unit to an electrical supply voltage outside of the specification.

The following wiring diagrams are a guide to installing the standard fan and actuator options found on NRG units. If in any doubt, or for special versions of the units, consult the wiring diagram in your document pack or contact our customer services department on **08448 15 60 60**, quoting the sales order (SO) number and unit type as found on the unit name plate.

For Three Phase Fans, a trial connection of the three phase supply should be made to check that the fan rotates in the correct direction as indicated on the fan. If the rotation is incorrect, interchange any two phases of the incoming supply at the terminal block. For incorrect rotation of single phase fans, check with the VES Service department for advice, on **08448 15 60 60**.

**Important**

Pre-wired units supplied in sections may require reconnection of numbered wires to either the isolator/control panel or, in the case of multiple sections, a local terminal box. For further information regarding fitted controls, please see the accompanying controls O&M.

### Standard Wiring Damper actuator wiring arrangement Fig. 13

230V 1PH 50Hz  
(24V 1PH 50Hz)

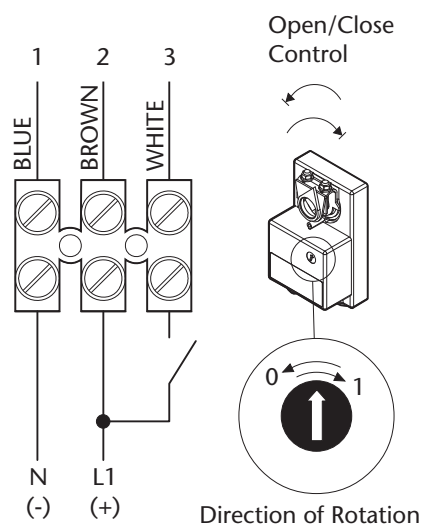

**Warning**

NM230A/NM24A Damper Actuator  
To isolate from the main power supply, the system must incorporate a device which disconnects all the phase conductors



# ecovent NRG Air Handling Units

## Installation, Operation and Maintenance Manual

### Standard Wiring & Fan Installation 5 Continued

Standard fan wiring arrangement Fig. 14

230V 1PH 50Hz

Model		230V 1PH 50Hz			
ecoNRG Unit	Fan	Motor Power (kW)	FLC (A)	SC (A)	C400V (μF)
0	ZB301	0.14	0.60	1.00	4
1	ZB401	0.49	0.93	1.70	6

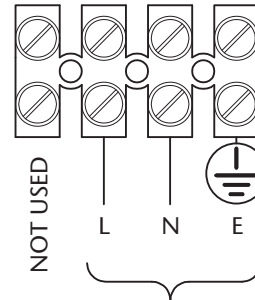

Customer Connections  
Electrical Supply 230V 1PH 50Hz

Standard fan wiring arrangement Fig. 15

230V 1PH 50Hz

Model		230V 1PH 50Hz			
ecoNRG Unit	Fan	Motor Power (kW)	FLC (A)	SC (A)	C400V (μF)
2	ZB501	0.40	1.70	4.50	8
3	SNS641	0.49	2.20	5.00	10
4	SNS641	0.49	2.20	5.00	10
5	SNS741	0.73	3.30	7.00	12
6	SNS841	1.30	5.70	15.0	30

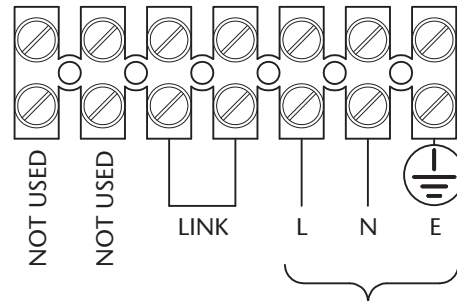

Customer Connections  
Electrical Supply 230V 1PH 50Hz

Standard fan wiring arrangement Fig. 16

400V 3PH 50Hz

Model		400V 3PH 50Hz		
ecoNRG Unit	Fan	Motor Power (kW)	FLC (A)	SC (A)
3	SNS643	0.32	0.51	0.97
4	SNS643	0.45	0.86	2.90
5	SNS743	0.69	1.30	3.40
6	SNS843	1.15	2.00	8.60

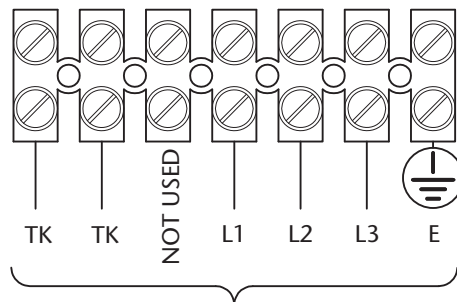

Customer Connections  
Electrical Supply 400V 3PH 50Hz

Standard fan wiring arrangement Fig. 17

400V 3PH 50Hz

Model		400V 3PH 50Hz		
ecoNRG Unit	Fan	Motor Power (kW)	FLC (A)	SC (A)
7	ZA0603	2.20	4.70	5.60
8	ZA0703	3.00	6.30	35.28
9	ZA0903	3.00	6.40	35.28

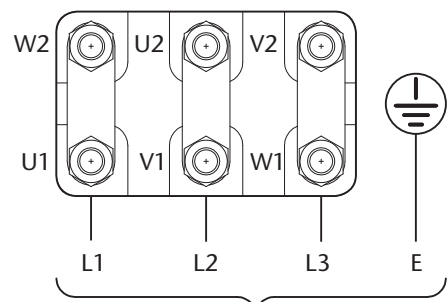

Customer Connections  
Electrical Supply 400V 3PH/Δ 50Hz



# ecovent **NRG** Air Handling Units

## Installation, Operation and Maintenance Manual

### Standard Wiring & Fan Installation

#### 5 Continued

Prior to starting the unit it is important to ensure that the fans are free running, and should any components have moved during transit take care to ensure they are realigned to allow correct operation/rotation. The same should be applied to any wiring looms which may have become unfastened; ensure that loose wiring is securely stowed away from any moving components. Inverter-driven plug fans are supplied as a balanced assembly and should not be disassembled, however the assembly is secured for transit with bolts as shown; these should be removed prior to start-up.

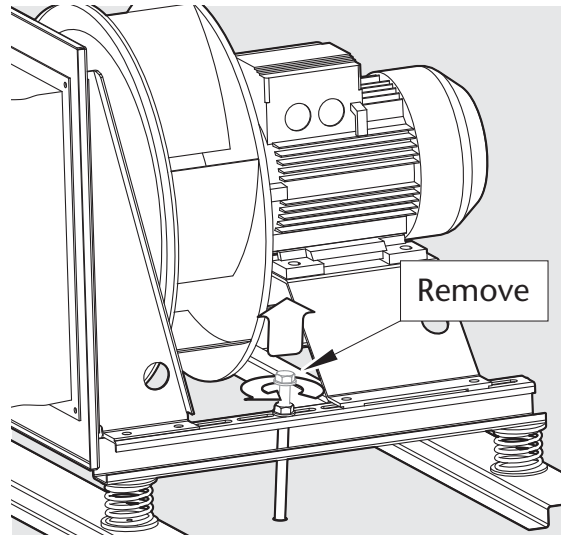

Typical plug fan set-up showing necessary transit bolt removal  
 Fig. 18

Typical plug fan set-up showing necessary transit bolt removal

Units size 0, 1 and 2 are supplied with a PS17 dual fan speed controller for commissioning; see the accompanying speed controller documentation for further operational details.

Units size 7, 8 and 9 are supplied with fitted 3phase inverters for fan speed control and commissioning; see the accompanying inverter documentation for further operational details. The centrifugal plug fans have infinite adjustment and when controlled by inverter, the benefits of real energy savings are apparent when the fan speed is reduced; this is best demonstrated when used in conjunction with additional sensors such as air quality or occupancy. Using a micro manometer and adjusting the fan speed via the inverter it is possible to commission each fan to the required air volume. Each fan section has a differential pressure tapping connection point; by connecting your micro manometer to the appropriate pitot a differential pressure reading can be taken.

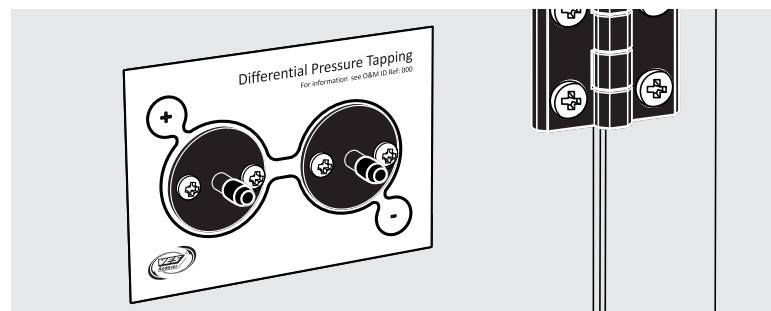

Differential Pressure Tapping point  
 Fig. 19

### Important !

This commissioning technique is only applicable to unit sizes 7, 8 and 9 with inverter control.



# ecovent NRG Air Handling Units

## Installation, Operation and Maintenance Manual

### Standard Wiring & Fan Installation 5

#### Continued

This differential pressure compares the static pressure in front of the fan inlet ring with the static pressure in the inlet ring of the narrowest point. The differential pressure between the static pressures is related to the air volume via the energy conservation rate as per the graph below. Simply read across from the pressure measurement to the appropriate fan curve and down to calculate the resultant air volume.

For example: Measured differential pressure: 550Pa  
 Unit: NRG766  
 Reading from graph: 1.0  
 Air Volume: 1.0m<sup>3</sup>/s

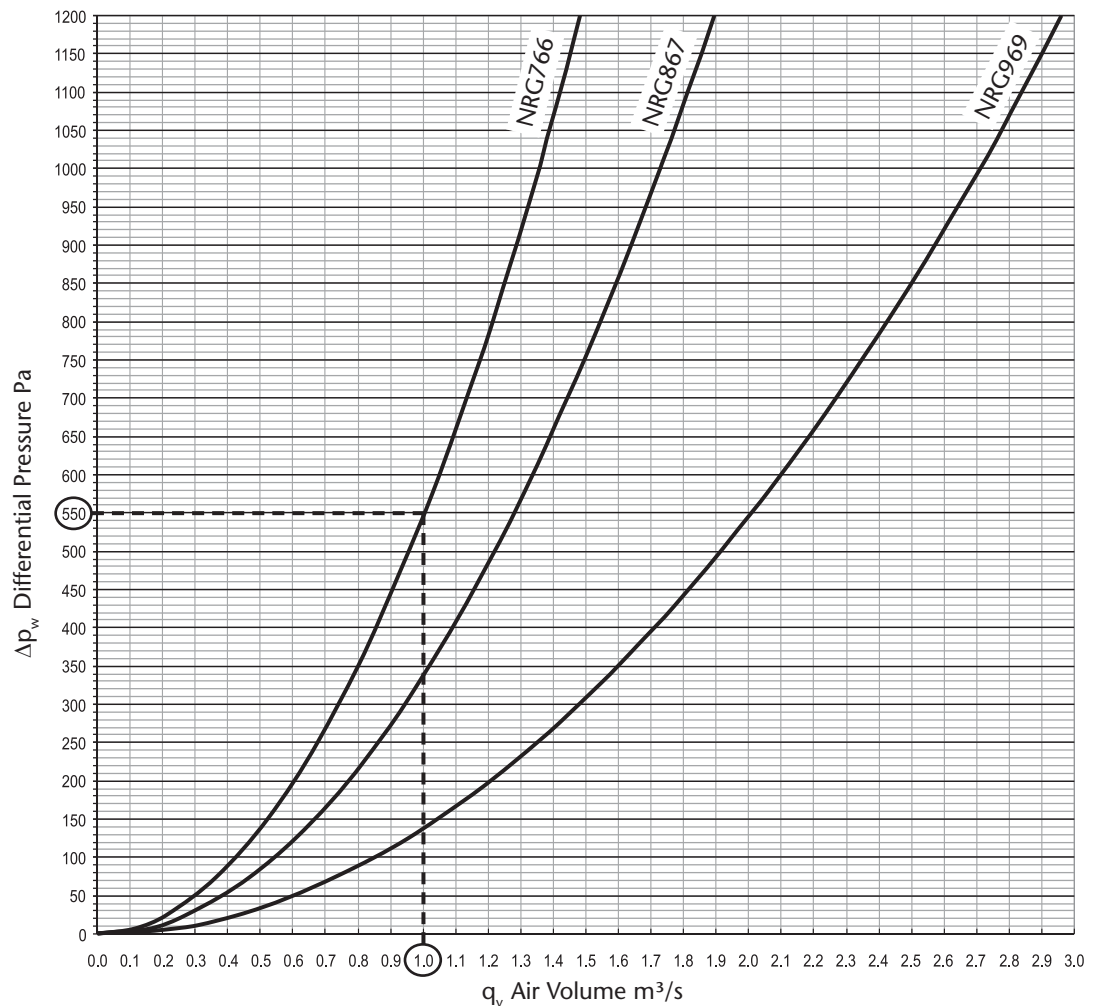

Differential Pressure Commissioning Graph Fig. 20

This measurement can also be expressed in the following calculation:

$$q_v = (k \sqrt{\Delta p_w}) / 3600$$

where  $q_v$  is the air volume in m<sup>3</sup>/s  
 $k$  is the fan nozzle coefficient (NRG766 = 154, NRG867 = 197, NRG969 = 308)  
 $\Delta p_w$  is the measured differential pressure in Pa

For example: Measured differential pressure: 550Pa  
 Unit: NRG766

$$q_v = (154 \sqrt{550}) / 3600$$

$$q_v = (154 \times 23.452) / 3600$$

$$q_v = 3611 / 3600$$

$$q_v = \text{air volume} = 1.003 \text{ m}^3/\text{s}$$





# ecovent **NRG** Air Handling Units

## Installation, Operation and Maintenance Manual

### Maintenance 6

#### Important

Before attempting to carry out any work on our units, all accompanying documentation including warning labels on the unit must be referenced.  
Should it be necessary to remove any component ensure that these are secured into position once reinstalled. It is critical that after any maintenance work has been conducted that all components removed/replaced be refitted correctly by a competent engineer

#### Warning

Before attempting to carry out any maintenance work, investigative or repair work on our units, the unit **MUST BE COMPLETELY ISOLATED** from its electrical supply. Ensure a minimum of two minutes after electrical disconnection before removing access panels. This will allow any moving parts to come to a rest.  
When used in conjunction with an Inverter for speed control, a minimum of **Five minutes** should be given to allow for the capacitors to discharge before starting work.

In general, this series of units require little maintenance. In the unlikely event of component failure, spares are available from stock at VES Andover Ltd.

#### Caution

When accessing the unit always use the handles to ensure the access panels are handled/opened in a controlled manner so as to avoid damage to the unit or injury to personnel. This is particularly important with bottom access units.  
Ensure the AHU has been allowed to completely cool before attempting any work to the unit

#### Recommended Checks

In order to keep the unit in good order the following maintenance routine is recommended:

#### Three Monthly Checks

Filters should be inspected every three months. If they are found to be heavily soiled or damaged in any way they should be replaced.

#### Six Monthly Checks

The fan impeller should be cleaned every 6 months. Failure to clean the fan on a regular basis could result in loss of fan performance, or cause it to fall out of balance. If a fan is stationary for long periods in a humid atmosphere, it should be switched ON for minimum of two hours every month to remove any moisture that may have condensed within the motor.  
Failure to keep dampers clean could result in the damper becoming inoperative. Clean damper blades, cogs and frames and lubricate with PTFE aerosol or equivalent.  
The heat exchanger matrix should be inspected for any debris, dust or dirt build up. If found contaminated, foreign matter should be removed accordingly; superficial dust or debris can be removed from the surface of the heat exchange by gently brushing. Loosened debris can then be vacuumed from the surface of the matrix or flushed through with warm water. Stubborn deposits can be removed by using a low pressure washer with an approved detergent solution. The solution temperature should not exceed 50 °C. When using any pressure device care must be taken not to damage the heat exchanger matrix.  
Under NO circumstances should the heat exchanger be steam cleaned. Ensure the drain pan and the drain connection is free from debris ensuring any condensate produced can freely drain away. Should a full service be required it may be necessary to disassemble the unit casework to gain access to some components.

#### Twelve Monthly Checks

NRG units are supplied with both unpainted galvanised sheet steel cases and powder coat paint finish. Check all painted items to ensure that they have not deteriorated, particularly where adverse environmental conditions prevail. Re-paint as necessary. Matching paint can be supplied upon request.

#### Spares & Repairs

When enquiring after or ordering spares contact VES Spares Department, quoting the sales order (SO) number and unit type as found on the unit nameplate.

**Tel: 08448 15 60 60 • Fax: 02380 26 12 04**

#### WEEE Directive



At the end of their useful life the packaging and product should be disposed of via a suitable recycling centre. Do not dispose of with normal household waste. Do not burn.

#### **PLEASE ENSURE THAT THIS DOCUMENT IS PASSED ON TO THE END USER**

We reserve the right to alter the specification without notice ©VES Andover Ltd. 2009.  
No part of this publication may be photocopied or otherwise reproduced without the prior permission in writing of VES Andover Ltd.





# ecovent **NRG** Air Handling Units

## Installation, Operation and Maintenance Manual



### **Declaration of Conformity**

Date: 1st. February 2009  
Product: ecoNRG air handling units  
Type: NRG  
Manufacturer: VES Andover Limited

The product above is produced in accordance with EC Council Directives:

2004/108/EC (Electromagnetic Compatibility Directive)

2006/95/EC (Low Voltage Directive)

98/37/EC (Machine Directive)

The European Harmonised Standards applied are:

BS EN ISO 12100, EN 294, EN61000, EN 60204-1, EN60950-1

Basis of Self attestation:

Quality Assurance to ISO 9001-2000, BSI Reg. Firm Cert. No. Q5375

Signature of Manufacturer:

Position of Signatory:

Technical Director



# ecovent **NRG** Air Handling Units

## Installation, Operation and Maintenance Manual

### Warranty

All VES Andover Products come with a one year guarantee from date of dispatch, which covers parts and labour.

You can now extend this with the following options:

Option 1. **FREE extended Warranty**

We can offer you a maintenance agreement that keeps this equipment in tip-top condition. If you take out this agreement, we will extend the warranty **free of charge for up to 5 years**, providing the regular maintenance agreement remains in place.

Option 2. **12-24 Month Extended Warranty**

12-24 months from the date of dispatch. This can be covered at a cost of just 3% of order value. (minimum charge £50.00).

Option 3. **12-36 Month Extended Warranty**

12-36 months from date of dispatch. For this cover, the charge is 6% of order value (Minimum charge £80)

Please State which option you require when you place your order. A transferable certificate will then be issued to you.

*Please note, this offer excludes condensing units. We would be happy to quote you for these separately.*

**Register for separate spares reminders and get a 10% discount**

Register for this free service and we will automatically send you a regular reminder detailing the consumable spares for this unit, together with their current list prices.

**You will then be entitled to a 10% discount off any spares.**

To arrange any of these options

**Phone: 08448 15 60 60**  
**or Email: spares@ves.co.uk**

Stating the sales order and reference number from the unit.