

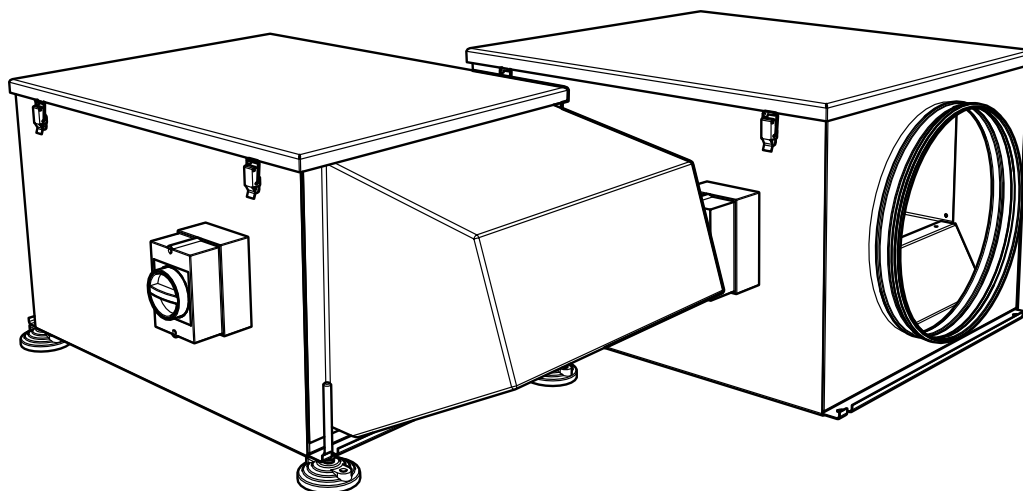



colourfan[®] Extract Unit

Installation, Operation and Maintenance Manual





Important  **This manual must be read in full before Installation, Operation and Maintenance of the units supplied**

Please ensure that this document is passed to the end user. This manual forms an integral part of the product and should be kept for the working life of the product. Additional copies of this and supporting documents are available by contacting VES or by visiting www.ves.co.uk and following the 'Information Centre' link.

The following symbols used within this document refer to potential dangers, advice for safe operation or important points of reference

Warning  Indicates hazards associated with electric current and high voltages

Caution  Indicates hazards that require safety advice for personnel or potential unit/property damage

Important  Indicates important information

		page	
Contents	1	Introduction	1
	2	Nomenclature	2
	3	Receipt of Goods & Handling	3
	4	Installation	3
	5	Standard Wiring & Fan Installation	6
	6	Maintenance	11
	7	Declaration of Conformity	13

Introduction **1** The **colourfan** extract series is a range of centrifugal extract units, direct driven with duties up to 2.5 m³/s. Suitable for plant-room, ceiling void and external locations. As standard, each unit will have been supplied pre-wired to an external isolator. The standard ambient operating temperature of the unit is -20 to +35 °C.

For further technical details regarding dimensions and weights, contact VES on **08448 15 60 60**, quoting the sales order (SO) number and the unit type as found on the unit nameplate, or alternatively visit www.ves.co.uk.



colourfan[®] Extract Unit

Installation, Operation and Maintenance Manual

Nomenclature Part Number Coding	2	Point Description	Point Variants	Details (as appropriate)
	1	Product	CLE	colourfan extract units
	2	Unit Size	0...9	Sequential see unit outline for details
	3	Fan Type	3	AC Backward curve centrifugal fan
	4	Fan Size	1...10	Sequential
	5	Phase	-1 -3	230V 50Hz Single Phase 400V 50Hz Three Phase
	6	Unit Configuration	/P /W	Plantroom (flat) Weatherproof (flat)
	7	Main Heating	Null	No Heating
	8	Infill	Null /AL	No Infill Optional acoustic liner
	9	Handing	/RT /RB /LT /LB	Right/Top Access Right/Bottom Access Left/Top Access Left/Bottom Access
	10	Main Filter	Null	No filter
	11	Control Panel Section	Null /I /ISC /IF /IFSC	No fitted controls Pre-wired isolator Pre-wired isolator & speed controller Isolator Fan Starter Isolator Fan starter & speed controller
	12	Inlet/outlet	/L /C /SP /CS	weather louvre outlet weather cowl outlet rectangular spigot circular spigot
	13	Colour	Null /R7004	Galvanised finish Powdercoated finish, RAL7004 etc...
	14	Powder Coat Type	Null /IT /BT	As colour Internal powdercoated only Internal/External powdercoated
	15	Special	/S	Special (non-standard) Unit

Typical Example

CLE031-1/P/AL/RT/I/CS/S

CLE 0 3 1 -1 /P /AL/RT /I /CS /S
 ① ② ③ ④ ⑤ ⑥ ⑦ ⑧ ⑨ ⑩ ⑪ ⑫ ⑬ ⑭ ⑮



colourfan[®] Extract Unit

Installation, Operation and Maintenance Manual

Receipt of Goods & Handling

3 Immediately upon receipt of goods, check for possible damage in transit paying particular attention to fan impellers, coil connections and unit casing. Prior to installation please check to ensure alignment and smooth rotation of the impellor after transit. Also check to ensure that any ancillary items are included. These will normally be supplied fitted or, in the case of small items, taped to the unit. In the event of any damage having occurred or if any item is found to be missing, it is essential to inform VES Andover Ltd. within **7 days** of delivery quoting sales order number and the unit type, as found on the unit nameplate. After this period, VES would be unable to accept any claim for damaged or missing goods.

Installation

4 The entire system must be considered for safety purposes and it is the responsibility of the installer to ensure that all of the equipment is installed in compliance with the manufacturer's recommendations, with due regard to the current HEALTH AND SAFETY AT WORK ACT and conforms to all relevant statutory regulations.

Where a unit is installed so that a failure of components could result in injury to personnel, precautions should be taken to prevent such an injury. If the unit is installed where there is a reasonable possibility of persons or objects coming into contact with the impellor whilst operational, a guard should be fitted or steps taken to prevent this. It is the installer's responsibility to ensure that access panels are not obstructed in any way and safe working access for maintenance must be provided in accordance with Health and Safety and Building Regulations. For confirmation of required access please see the appropriate unit outline drawing.

For optimum unit performance, careful consideration must be paid to the location of the unit in relation to the ductwork and associated items; placing the unit directly adjacent to a bend in ductwork will impede airflow and reduce performance. Consideration must also be given by the installer for adequate illumination of the unit location in order for safe maintenance. Further consideration should be given to the unit's position and should be secured into place as appropriate; this is especially important with external mounting as the wind and elements may effect the overall stability of the unit.

Caution



Handles, lids, housings and coil connections must NOT be used as lifting points

Lifting Details

Fig. 1

When moving the unit, handle with care and in such a manner as to avoid damaging the external finish as this may reduce the ability to resist corrosion.

Units are to be rigged and lifted using spreaders, taking into account the weight of the unit. Lifting gear should be arranged so as not to bear on the casework 1.

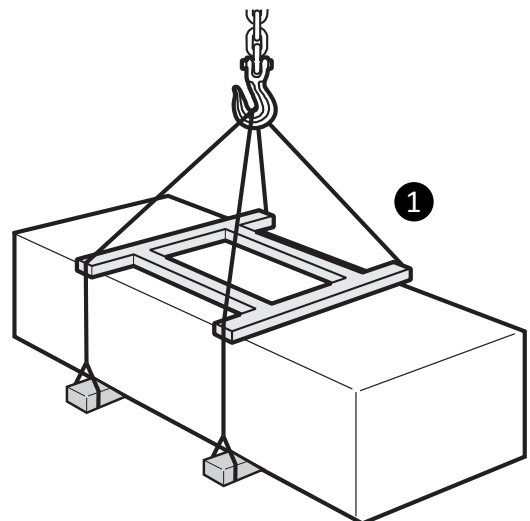

Caution



Units should only be supported using the support feet as provided by VES with the unit. Contact VES before attempting to support the unit using alternative methods.

Only experienced fitters should undertake this work. Take necessary safety precautions when working in elevated positions.



colourfan[®] Extract Unit

Installation, Operation and Maintenance Manual

Installation 4 Continued

Colourfan extract units are supplied with feet suitable for floor or ceiling-void mounting, either by use of drop-rod mounting, in either top or bottom access orientation, with airflow in the horizontal plane. For alternative mounting please consult your outline drawing as supplied with the unit, or refer to VES Customer Services for further information.

Unit mounting options

Fig. 2 3 4 5

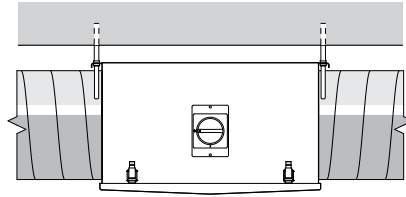

2 Plantroom ceiling mounted

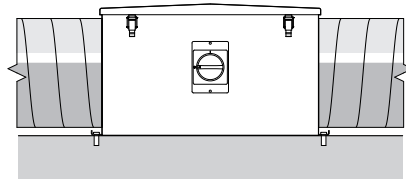

3 Plantroom floor mounted

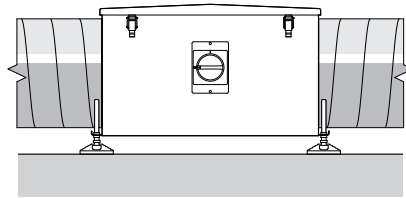

4 Plantroom floor foot mounted

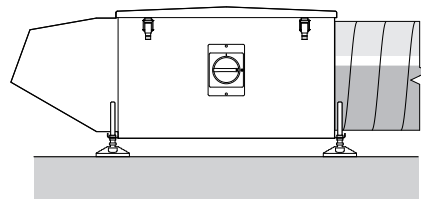

5 Weatherproof/roof mounted



colourfan[®] Extract Unit

Installation, Operation and Maintenance Manual

Installation 4 Continued

Secure drop rods/unit with M10 fixings as shown **6**.
Self-levelling feet are available for floor mounting, with M10 fixings as per drop rods **7**.
If required the unit can be further secured to the floor via knockout fixing holes on the feet, fixings to be supplied by others **8**.
Note: max/min dimensions for foot height **9**.

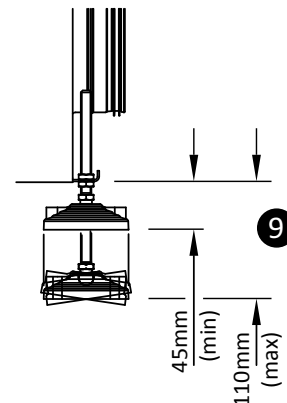

Unit mounting detail

Fig. **6 7 8 9**

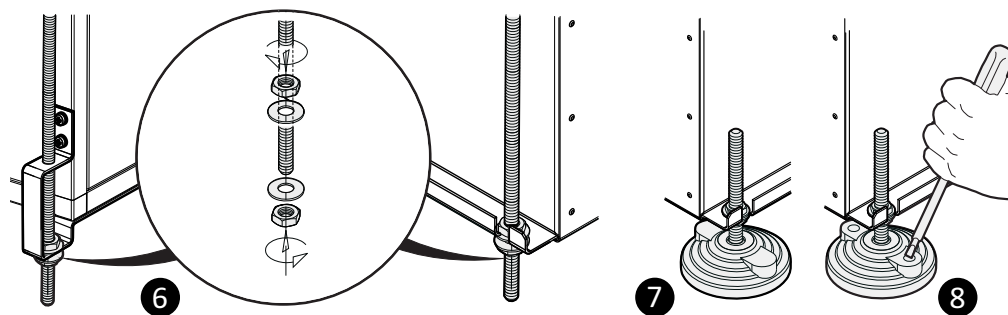

Important



When hanging units from drop-rods, ensure that the load is evenly spread and that all feet are used within the support. It is important that the unit is level to ensure all components operate correctly.

Where provided, flanges and spigots should not be used to support the ductwork and used solely as a means of ductwork connection. Further consideration should be given to the unit's position and secured into place as appropriate.

Important



Units are supplied with customer connections as specified at time of order. Should you need to alter this please consult VES as unit adjustment may invalidate your warranty.



colourfan[®] Extract Unit

Installation, Operation and Maintenance Manual

Standard Wiring 5 & Fan Installation

Warning



The electrical supply **must be fully isolated** before attempting to affect any work on this unit. All electrical connections to any unit must be carried out in accordance with the current edition of the I.E.E Regulations, only competent Electricians should be allowed to affect any electrical work to our units.

Important



It is the customer's responsibility to supply earth fault protection through the building installation device and a dedicated, isolated power supply with overload protection, to account for motor start up currents. See the fan wiring diagram for specific fan details on page 7 and 9 Fig. **10 13**.

Warning



Do not connect any unit to an electrical supply voltage outside of the specification.

For Three Phase Fans, a trial connection of the three phase supply should be made to check that the fan rotates in the correct direction as indicated on the fan. If the rotation is incorrect, interchange any two phases of the incoming supply at the isolator. For incorrect rotation of single phase fans, check with the VES Service department for advice, on **08448 15 60 60**.

The following wiring diagrams (*page 7, 8, 9 & 10*) are a guide to installing the standard fan options found on colourfan units. If in any doubt, for units with fitted VES controls or for special versions of the units, consult the wiring diagram in your document pack or contact VES Customer Services Department on **08448 15 60 60**, quoting the sales order (SO) number and unit type as found on the unit name plate.



colourfan® Extract Unit

Installation, Operation and Maintenance Manual

Standard Wiring & Fan Installation

Standard fan details
 230 VAC 50Hz
 Fig. 10

5 Continued

Model		230 V 1PH 50Hz			
colourfan Unit	Fan	Motor power (KW)	FLC (A)	S (A)	C400V μ F
031-1	ZC0101	0.06	0.26	0.48	2
132-1	ZC0201	0.10	0.45	0.82	2.5
233-1	ZC0301	0.20	0.86	1.70	6
334-1	ZC0401	0.11	0.53	1.20	4
435-1	ZC0501	0.14	0.62	0.90	4
536-1	ZC0601	0.27	1.30	3.90	6
637-1	ZC0701	0.43	1.90	5.00	10

Standard wiring arrangement
 Isolator Termination
 230 VAC 50Hz
 Fig. 11

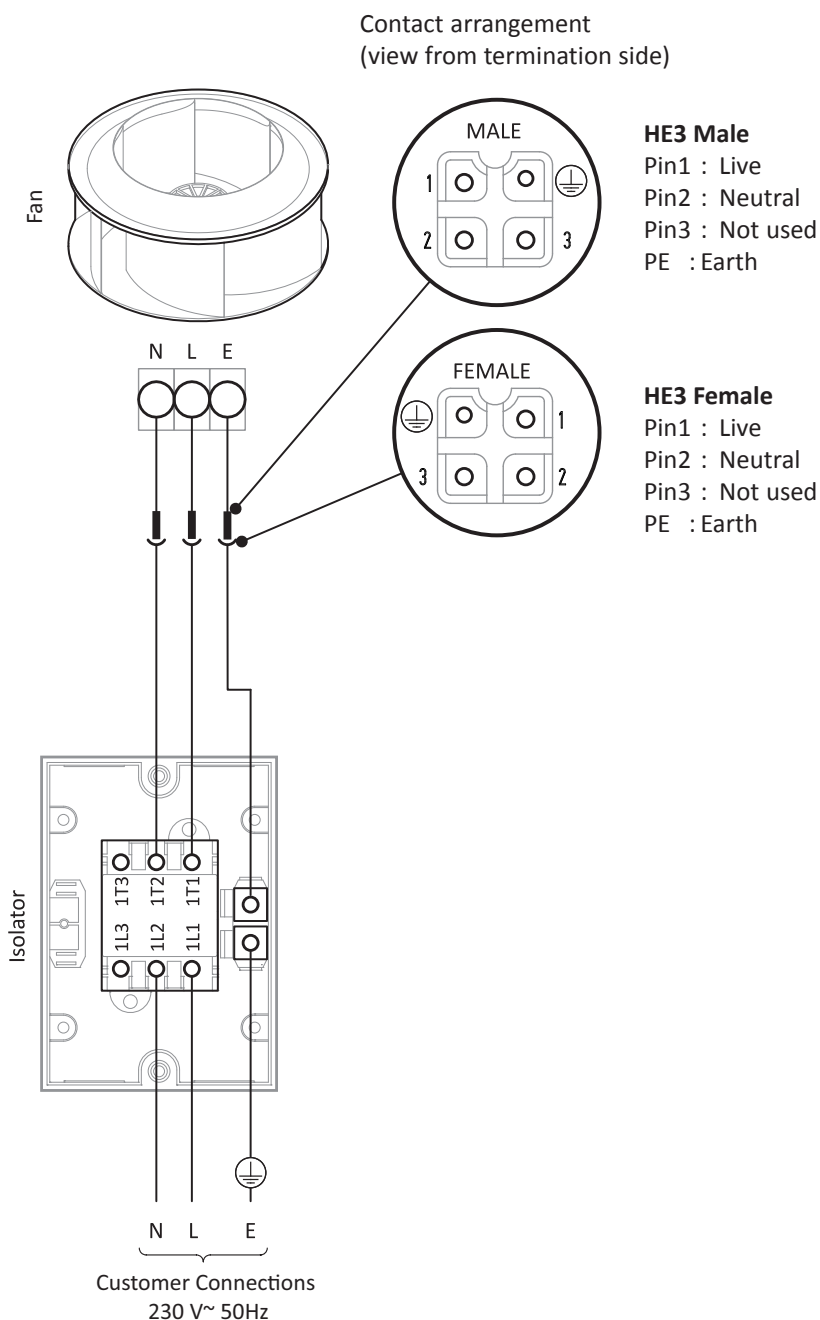



colourfan[®] Extract Unit

Installation, Operation and Maintenance Manual

Standard Wiring & Fan Installation

5 Continued

Standard wiring arrangement
 Isolator Termination
 230 VAC 50Hz
 c/w speed controller
 Fig. 12

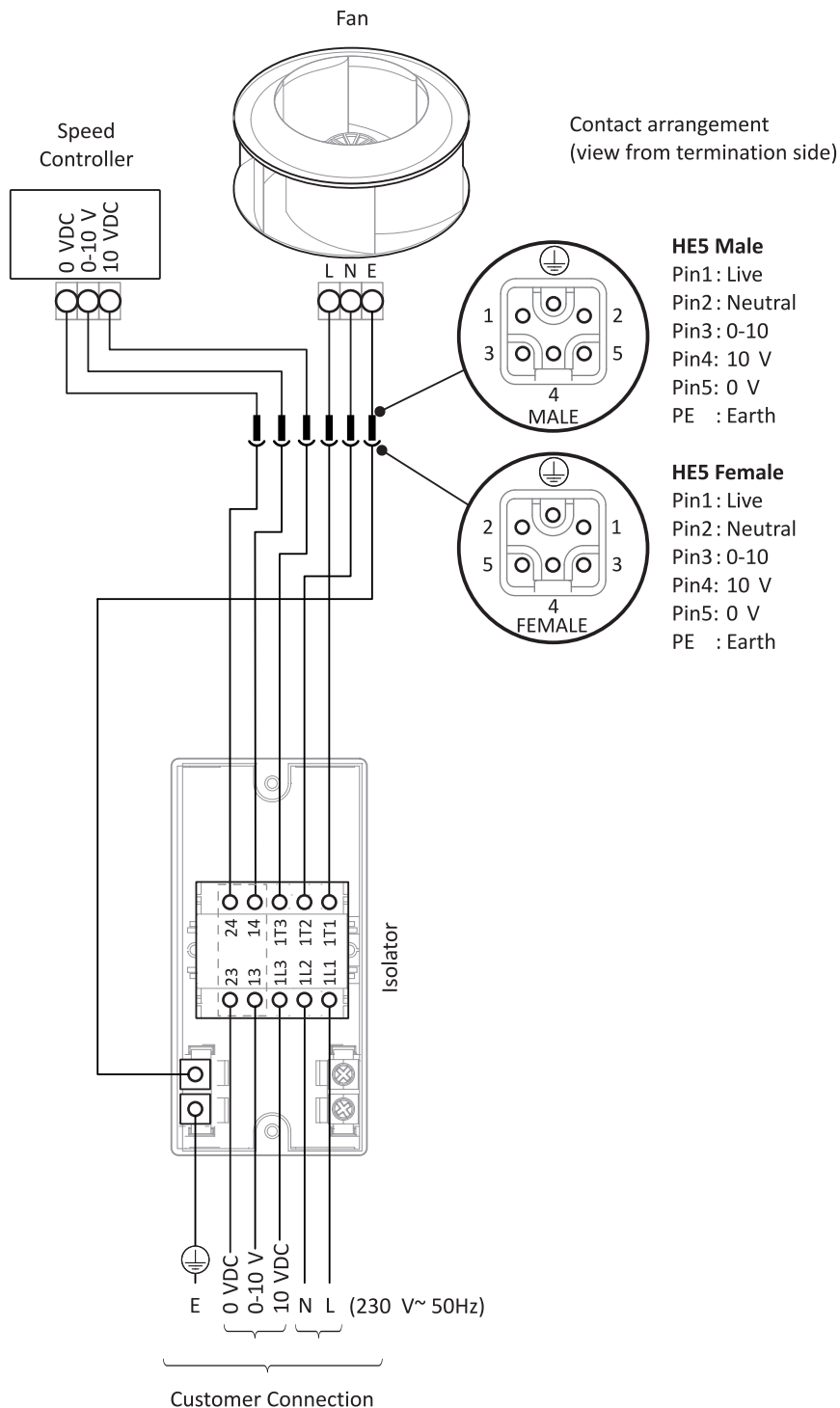



colourfan[®] Extract Unit

Installation, Operation and Maintenance Manual

Standard Wiring & Fan Installation

Standard fan details
 400 V Three Phase
 Fig. 13

5 Continued

Model		400 V 3PH 50Hz		
colourfan Unit	Fan	Motor power (kW)	FLC (A)	S (A)
637-3	ZC0703	0.44	0.78	2.70
738-3	ZC0803	0.64	1.30	4.30
839-3	ZC0903	1.20	2.10	8.60
9310-3	ZC1003	1.70	3.30	12.60

Contact arrangement (view from termination side)

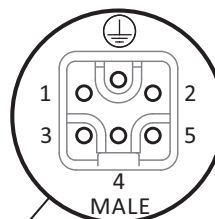
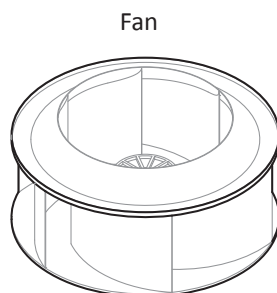

HE5 Male
 Pin1 : N/A
 Pin2 : N/A
 Pin3 : L1
 Pin4:L2
 Pin5:L3
 PE :Earth

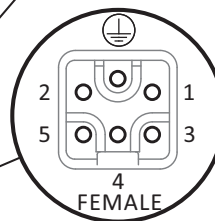

HE5 Female
 Pin1 : N/A
 Pin2 : N/A
 Pin3 : L1
 Pin4:L2
 Pin5:L3
 PE :Earth

Standard wiring arrangement
 Isolator Termination
 400 V Three Phase
 Fig. 14

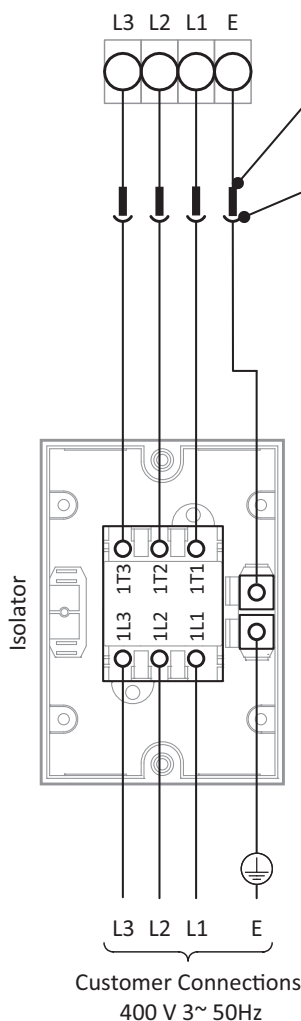

Important For associated components (speed controllers, etc.) please refer to the relevant accompanying O&M



colourfan® Extract Unit

Installation, Operation and Maintenance Manual

Standard Wiring & Fan Installation

5 Continued

Standard wiring arrangement
Isolator Fan starter
 230 VAC
 Fig. 15

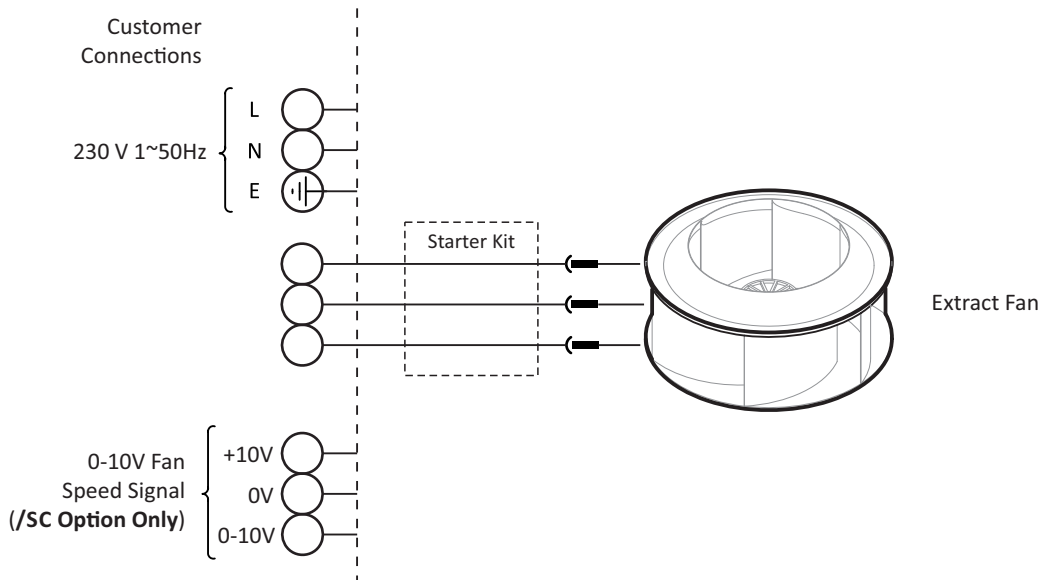

Standard wiring arrangement
Isolator Fan starter
 400 V Three Phase
 Fig. 16

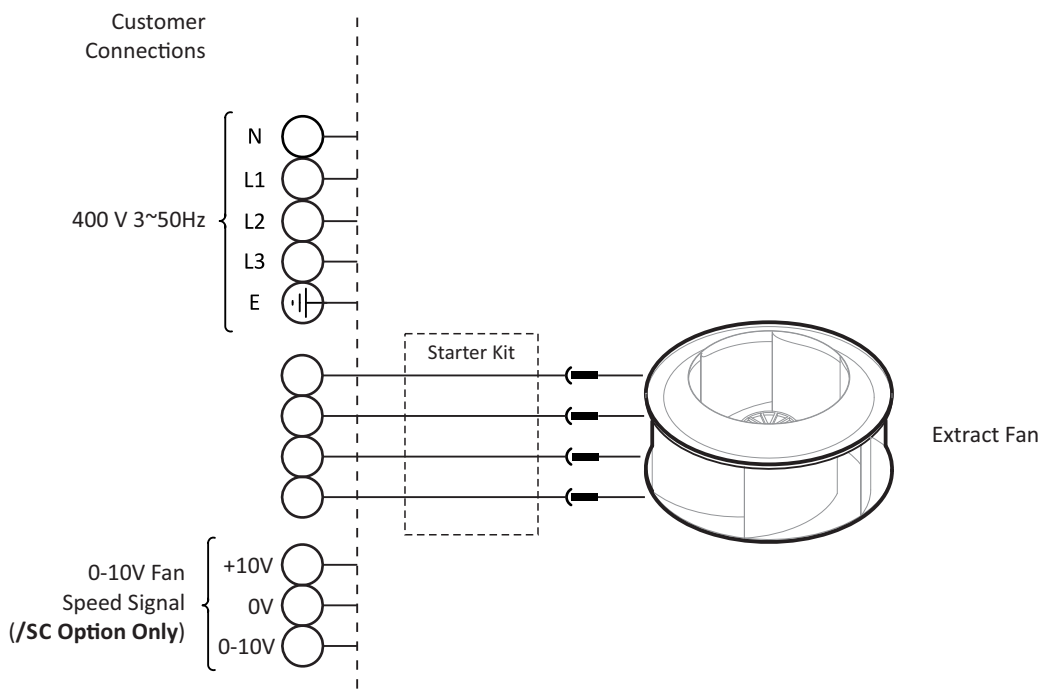



colourfan[®] Extract Unit

Installation, Operation and Maintenance Manual

Maintainance 6

Important



Before attempting to carry out any work on our units, all accompanying documentation including warning labels on the unit must be referenced.

Should it be necessary to remove any component, ensure that these are resecured into position once reinstalled. It is critical that after any maintenance work has been conducted that all components removed/replaced be refitted correctly by a competent engineer.

Warning



Before attempting to carry out any maintenance work, investigative or repair work on our units, the unit **MUST BE COMPLETELY ISOLATED** from its electrical supply. Ensure a minimum of two minutes after electrical disconnection before removing access panels. This will allow any moving parts to come to a rest.

When used in conjunction with an Inverter for speed control, a minimum of **Five minutes** should be given to allow for the capacitors to discharge before starting work.

Care should also be taken when accessing external units as the wind and elements may cause moving parts to 'windmill'.

Caution



When accessing the unit ensure the access panels/lids are handled/opened in a controlled manner so as to avoid damage to the unit or injury to personnel. This is particularly important with bottom access units.

Care should be taken with larger unit lid removal as this may need to be undertaken by more than one person.

Caution



lifting Hazard: Due the size and weight of larger fans take extra care during removal/installation. Multiple persons are advised for this operation to avoid injury.

Fan assembly removal

Colourfan units feature plug & socket connections to allow easy fan assembly removal should it be required. Follow the instruction below.

Ensure the unit is fully isolated from the electrical supply. Carefully remove the lid by unfastening the side catches around the casework. Separate the plug connection by hand (tools not required) by lifting the locking lever and pulling the plug/socket apart **17**. **DO NOT** pull the cable to separate the assembly. Remove and retain the four fan plate fixings **18**.

Carefully lift out the fan assembly; removal of the fan plate cover is not normally required **19**.

Plug Connector
Locking/Unlocking
Fig. **17**

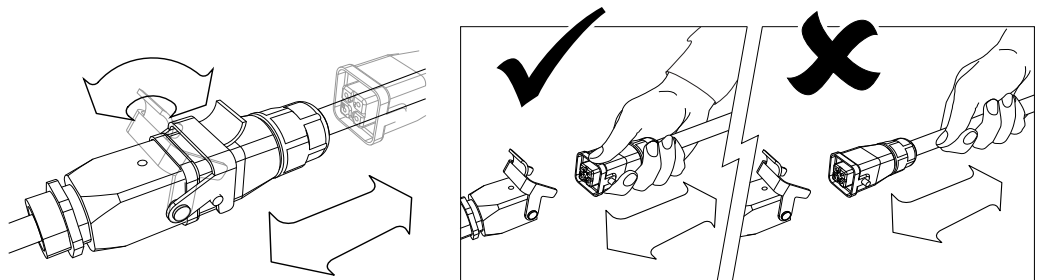



colourfan[®] Extract Unit

Installation, Operation and Maintenance Manual

Maintenance Fan assembly installation

6 Continued

Replace the fan assembly onto the fan bulkhead; a small stud has been included to assist with correct location. When returning the fan assembly to the case take care not to drop the fan impellor on the inlet eye as incorrect alignment may damage the impellor. Secure the fan plate with the appropriate fixings, ensuring correct fan alignment with the inlet eye, adjusting as necessary **20**. A trial spin by hand should indicate if the fan is rubbing. To align, loosen the fan plate fixings, adjust and retighten. It is important that the loom is secured away from the fan impellor (coil excess cable and zip tie loom to fan plate as appropriate), allow enough slack for loom connection/removal to fan socket. On reconnection, the plug assembly features a locating lug to ensure correct orientation. Once rejoined, lock the connection together again using the locking lever as shown **17**. Carefully replace the lid and ensure all fixings are safely refastened.

Fan assembly removal/ installation
Fig. **18** **19**

Fan alignment
Fig. **20**

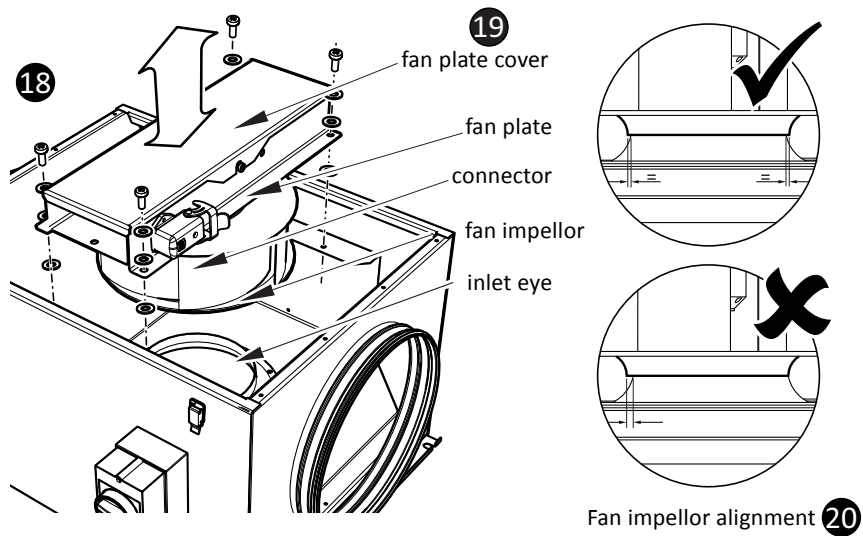

Three Monthly Checks

In order to keep the unit in good order the following maintenance routine is recommended:

Check inside the unit for accumulation of dust, grease etc. If the fan impellor is heavily soiled, clean out carefully (ensure the unit is properly isolated). Failure to do this periodically could lead to a loss of performance or the fan to become out of balance, leading ultimately to bearing failure. If the fan is stationary for long periods in a humid atmosphere, the unit should be switched ON for minimum of two hours every month to remove any moisture that may have condensed within the motor.

Six Monthly Checks

The security of fastenings and the integrity of components should be checked regularly as part of the routine maintenance operation. Colourfan units are supplied with both unpainted galvanised sheet steel cases and powder coat paint finish. Check all painted items to ensure that they have not deteriorated, particularly where adverse environmental conditions prevail. Re-paint as necessary. Matching paint can be supplied upon request.

Spares & Repairs

When enquiring after or ordering spares contact VES Spares Department, quoting the sales order (SO) number and unit type as found on the unit nameplate.

Tel: 08448 15 60 60 • Fax: 02380 26 12 04

WEEE Directive

At the end of their useful life the packaging and product should be disposed of via a suitable recycling centre. Do not dispose of with normal household waste. Do not burn.

PLEASE ENSURE THAT THIS DOCUMENT IS PASSED ON TO THE END USER

We reserve the right to alter the specification without notice ©VES Andover Ltd. 2013. No part of this publication may be photocopied or otherwise reproduced without the prior permission in writing of VES Andover Ltd.





 **colourfan[®] Extract Unit**
Installation, Operation and Maintenance Manual

CE *Declaration of Conformity*

Date: 7th May 2013
Product: colourfan Air Handling Unit
Type: C L E
Manufacturer: VES Andover Limited

The product above is produced in accordance with EC Council Directives:

2004/108/EC (Electromagnetic Compatibility Directive)

2006/42/EC (Machine Directive)

The European Harmonised Standards applied are:

BS EN ISO 12100, BS EN ISO 13857:2008, EN61000, EN 60204-1, BS EN 60950-1:2002

Basis of Self attestation:

Quality Assurance to ISO 9001-2008, BSI Reg. Firm Cert. No. Q5375

Signature of Manufacturer:

Position of Signatory:

Director